

## CONNECTING BLOCKS AND WIRING BLOCKS—88-TYPE

### 1. GENERAL

**1.01** This section covers the identification, installation, and maintenance of the 88-type wiring blocks and 88-type connecting blocks for terminating inside wiring cables.

**1.02** This section is reissued to:

- Include information on the 88P-type patch cords
- Replace the 788B1 tool (MD) with the 788B2
- Replace the 788D3 tool (MD) with the 788D4
- Add new Fig. 9
- Add new Table B
- Make minor text changes.

**1.03** The 88-type wiring and connecting blocks are compact connecting blocks designed for key telephone systems or similar installations. They may be used at any indoor locations now employing the 66-type blocks and associated backboards. The wiring blocks are modular, with terminations in a 25-pair, even-count, color-code basis. They reduce wall space requirements, installation time, improve pair identification, and permit easy expansion of cross-connect fields. Cables are terminated on the wiring block index strip on a permanent basis; rearrangements and changes are made with cross-connect wire on the top side of the connecting blocks.

**1.04** Information for installing and wiring connecting blocks, using the 88-type connecting and

wiring blocks in Outside Plant application, is not covered in this practice. Refer to Section 631-050-120.

**1.05** For information about protective devices used on special service circuits requiring Special Service Protection or Special Safeguarding Measures, refer to Section 460-110-100.

**1.06** Information on key telephone systems, wiring methods for 88-type wiring blocks, and typical running cable arrangements for key system installations, will be found in Section 518-010-101.

### 2. IDENTIFICATION

#### 88-TYPE WIRING BLOCK

**2.01** The 88-type wiring block (Fig. 1) is made of flame retardant plastic with molded index strips. Separate backboards are not required. Each index strip has 50 slots to accommodate a 25-pair cable or a color binder group for terminating PE or PVC 22-, 24-, 26-gauge wire without removing insulation. The index strips are color-coded white, red, black, yellow, violet, from left to right, in 5-pair segments to match the color coding for tip conductors of even-count cables. The various parts of the wiring block are shown in Fig. 1.

**2.02** The letters and numbers (eg, 88AW1-100) of the complete code designation provide the following information:

- (1) 88—basic type of terminal block.
- (2) The first suffix letter indicates basic style as follows:

A—legs with feet - single connections

#### NOTICE

Not for use or disclosure outside the  
Bell System except under written agreement

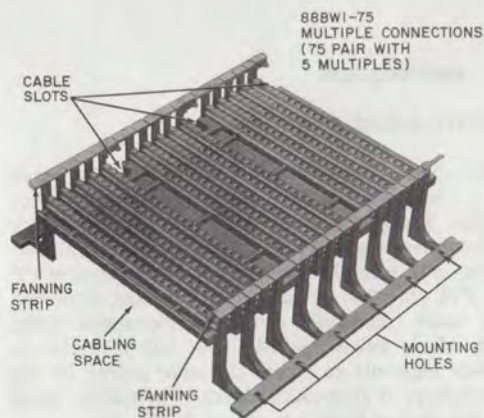
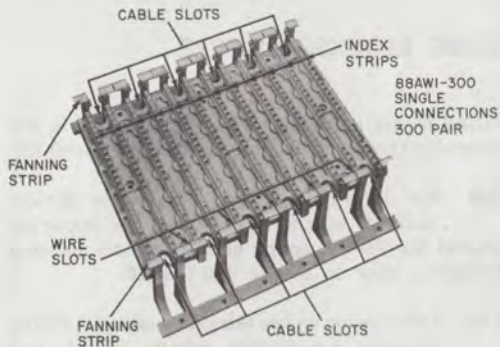

Fig. 1—88-Type Wiring Block

B—legs with feet - 5 connections (multiple).

The A and B styles are for wall mountings on customer premises.

- (3) The second suffix letter denotes color of the wiring block: W—indicating white.

**Note:** All codes of 88-type wiring blocks are supplied in white only. The application of the block is indicated by the use of colored designation strips (separately ordered), which come in blue, red, yellow, green, and purple.

- (4) The third suffix numeral assignment is to identify minor design differences resulting from engineering or manufacturing improvement.
- (5) The number following the dash indicates the number of pairs that can be terminated.
- (6) The letter C following the number of pairs indicates the block is supplied with a factory-wired connector-ended cable 5 feet long (Fig. 2). The blocks are factory-wired to give five multiples for each conductor. On prewired blocks, extra multiples can be provided using the 3-way bridging adapter, KS-19252,L2 (PCP), for no more than ten multiples. Refer to Section 461-200-101 for information on adapters.

2.03 The wiring blocks used in key system applications are shown in Table A.

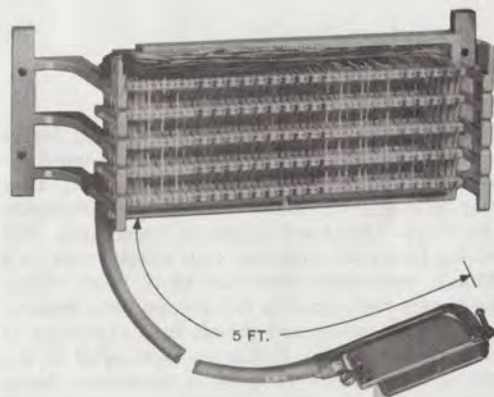

Fig. 2—88-Type Wiring Block With Connector Cable

#### 88-TYPE CONNECTING BLOCK

2.04 The 88-type connecting block (Fig. 3) consists of a flame retardant, plastic-molded housing equipped with double-ended, quick-clip metal connectors. When mounted on the wiring block, the bottom end makes connection with the cable conductors in the index strip, and the top end provides connections for cross-connect wires. They are available in 3- and 5-pair blocks. The clips for terminating the cables are designed to terminate



TABLE A

## WIRING BLOCKS AND CONNECTING BLOCKS

CODE (NOTE)	COLOR	CAPACITY (PAIRS)	TYPE	APPLICATION	SIZE (INCHES)
88AW1-100	White	100	Wiring Block	All Fields	10-3/4 X 3-1/2
88AW1-300		300			10-3/4 X 10-3/4
88BW1-25		25*		Red Field	10-3/4 X 3-1/2
88BW1-25C		25*			10-3/4 X 3-1/2
88BW1-75		75†			10-3/4 X 10-3/4
88BW1-75C		75†			10-3/4 X 10-3/4
88BSW1-3 88BSW1-5	Slate/White	3 5	Connecting Block	All Wiring Blocks	7/8 X 1-1/2

Note: Code ending in C indicates block is supplied with a 5-foot length of connector cable terminated.

\* Five multiples of one 25-pair cable.

† Five multiples of three 25-pair cables.

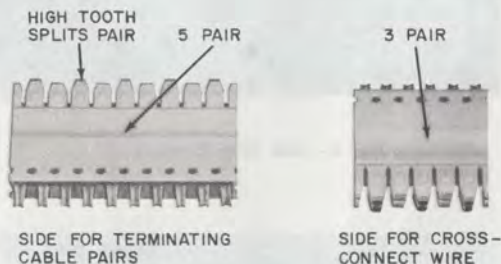

Fig. 3—88-Type Connecting Block

PE or PVC 22-, 24-, or 26-gauge wire without the removal of insulation.

**2.05** The following is the coding arrangement for the 88-type connecting block. The letters and numbers (eg, 88BSW1-5) of the complete code designation provide the following information.

- (1) 88—basic type connecting block.
- (2) The first suffix letter indicates basic style; ie, the letter B indicates that the clips are gold-plated and protrude from one side of the connecting block.

(3) The second and third suffix letters denote color; this is a double letter for two color blocks. The codes presently assigned are SW (Slate White—one side slate, one side white).

(4) The third suffix numeral is assigned to identify minor design difference resulting from engineering or manufacturing improvement.

(5) The number following the dash indicates the number of pairs (three or five pairs).

**2.06** The different colored sides of connecting blocks aid in pair identification when installed on the wiring blocks as outlined in paragraph 3.17. Connecting blocks are shown in Table A.

#### ASSOCIATED APPARATUS

**2.07** The 188B1-type backboard (Fig. 4) is used to provide a horizontal wiring channel for cross-connect wire in large installations. The backboard consists of two plastic distributing rings mounted on a white sheet metal panel 1/2-inch thick by 10-3/4 inches long by 6-1/2 inches wide. The 188B1 backboard replaces the 188A1 which is rated MD.

**2.08** The AT-8660 F clip terminal insulator (Fig. 5) is used to mark special service circuits requiring Special Service Protection or Special Safeguarding Measures. The F clip terminal insulator

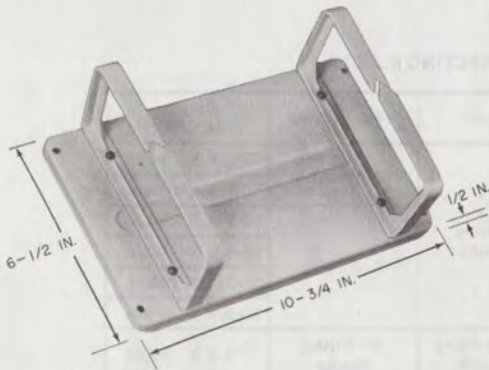

Fig. 4—188B1 Backboard

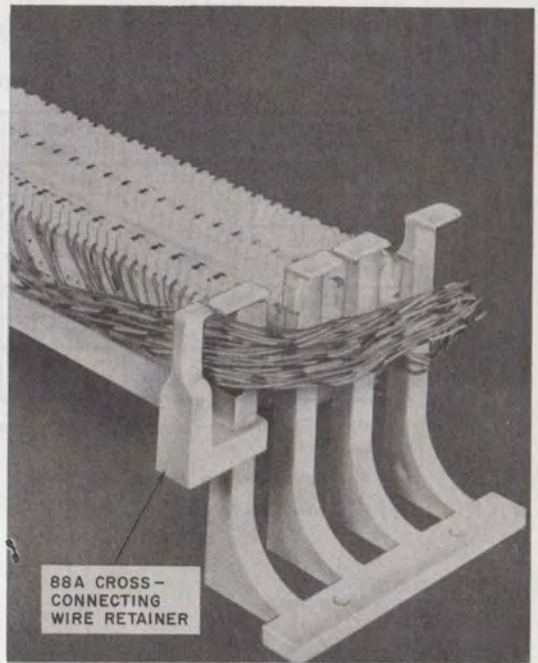

Fig. 6—88A Wire Retainer



Fig. 5—AT-8660 F Clip Terminal Insulator

mechanically protects one pair and may be located in adjacent pair positions without interference to protect any number of pairs.

**2.09** The 88A wire retainer (Fig. 6) is used on top- or bottom-mounted blocks to form a fanning strip slot for the cross-connect wire.

**2.10** The C test cord (Fig. 7) is attached to a wall-mounted 101B2 wire terminal, located so the cord plug will reach all 88-type blocks, and is left in place for testing purposes. The cord is now made in 4- and 8-foot lengths to facilitate reaching all terminations in large distributing fields.

**2.11** The B key equipment test block can be used to test CO/PBX line circuits in 1A1 or 1A2

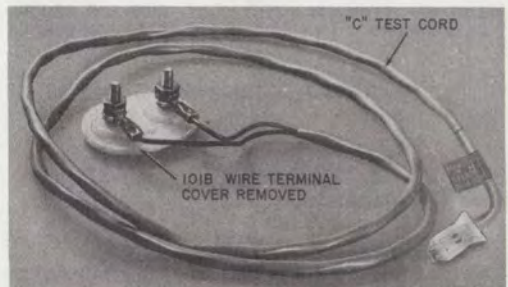

Fig. 7—C Test Cord and Terminal Block

Key Telephone Systems (KTSs). The test block (Fig. 8) can be used on 88-type connecting blocks in the red or blue fields with or without jumpers terminated on the connecting block. Spring-loaded probes make connection with the contacts associated with T, R, A, A1, LG, and L on the station side



of the line circuit. The test block is also equipped with two lamps (T/R and LP), a pushbutton (H), and a 2-position slide switch (TST-TLK). Two terminals on the sides of the test block are provided for connecting a 1013A or equivalent hand test set. Use of the test block is covered in Table D.



Fig. 8—B Key Equipment Test Block

#### ♦PATCH CORDS

2.12 The 88P-type patch cords (Fig. 9) are intended primarily for use with the Customer Administered Terminal Move Service (CATMS), but may have applications with other installations of 88-type wiring and connecting blocks. They are available with 1, 2, or 3 pairs in fifteen discrete lengths from 25 to 235 centimeters. Stranded 24-gauge wire with PVC insulation is used. Attached to each end of the patch cord is a fire-resistant plastic connector which plugs into an 88-type connecting block mounted on the front of a wiring block. The connector is designed to fit over the teeth of the connecting block in such a way that pair alignment is maintained. The word "TOP" is visible on the white upper side of each connector to assure that leads are not reversed. The 88P-type patch cords are reusable and require no tools for installation or removal. A complete list of patch cords is contained in Table B.

2.13 The letters and numbers (eg, 88P4A2A) of the complete code designation provide the following information:

- (1) 88—part of 88 connective system hardware.
- (2) P—CATMS patch panel application.
- (3) Single digit—number of conductors.

- (4) Single letter—major design changes.
- (5) Double or single digits—cord length code.
- (6) Single letter—minor design changes.

2.14 In addition to the 88P patch cords, the CATMS utilizes special purpose 88-type hardware not covered in this section. Refer to Section 917-454-401 for CATMS ordering information and engineering planning guidelines. Equipment installation instructions are covered in Section 461-617-100.♦

#### TOOLS

2.15 The 5-pair insertion tool (Fig. 10) consists of the ♦788B2♦ tool head mounted in the 788A1 tool handle. The tool head is used to seat five cable pairs at one time or to insert 3- or 5-pair connecting blocks on the index strip of the wiring block.

2.16 The 788C1 cutoff tool head (Fig. 11) mounts in the 788A1 tool handle and is used to cut five cable pairs at one time on the index strip after proper insertion.

2.17 The single pair insertion tool ♦(788D4)♦ is supplied as a combination of the handle and insertion head. The reversible ends of the head provide either insertion/cutoff or insertion only (Fig. 12) of a single cable pair.

2.18 The 788J1 impact tool (Fig. 13) is used to perform the same functions as the 788B2 and 788C1 tools, but it has a spring-loaded handle designed to supply the proper impact force to seat and cut off conductors or to insert the connecting blocks. The blade section of the head is easily removed for replacement or positioning for wire seating/cutoff or seating only. The 88-type connecting blocks should be placed on the index strips, by hand, before insertion, using the tool. The 788J1 tool replaces the 788H1 which is rated MD.

2.19 The 788K1 lead retention tool is used when it is necessary to remove the 88-type connecting blocks from the index strips of the wiring blocks. The blade of the tool is used to hold the wires in place in the index strips (Fig. 27) while the connecting block is being removed as shown in paragraph 4.02.

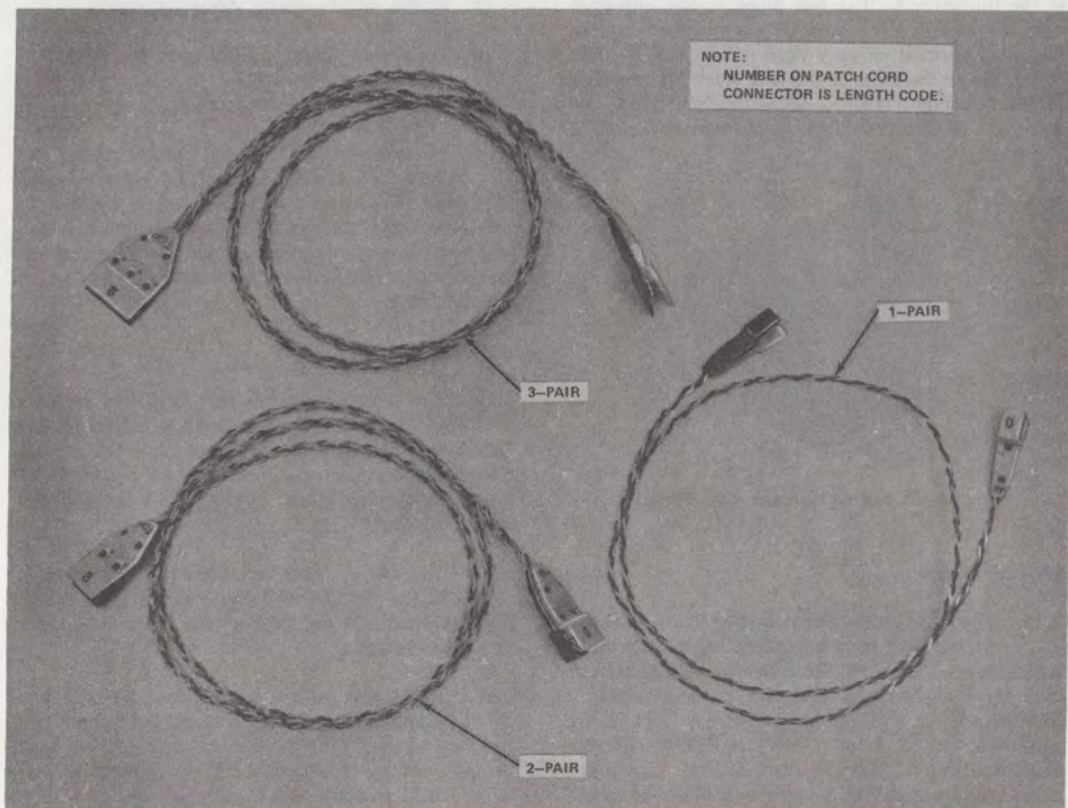

Fig. 9—88P-Type Patch Cords

**2.20** The D impact tool (Fig. 14) consists of a handle with an adjustable impact force and a cavity for storing an extra blade. Double-ended blades are available which permit insertion/cutoff or insertion only of single conductors on 88-, 66-, or 630-type connecting blocks. Two knurled wheels are provided in the tool handle—one to adjust the impact force depending on wire gauge and type of connecting block; the other to expose the opening for the extra blade storage. The D impact tool is used to cut off and/or seat single conductors on the connecting blocks.

#### ORDERING GUIDE

##### Blocks and Tools

- Block, Wiring, 88-Type (refer to Table A)
- Block, Connecting, 88-Type (refer to Table A)
- Tools (refer to Table C).

#### Associated Apparatus

- Strip, Designation

188AB1-100 (blue, two per package—pre-designated 1 to 100)

188AG1-100 (green, two per package—pre-designated 1 to 100)



♦TABLE B♦

## PATCH CORDS

COMPLETE APPARATUS CODE DESIGNATION			LENGTH CODE (NOTE)	LENGTH	
1-PAIR (2-CONDUCTOR)	2-PAIR (4-CONDUCTOR)	3-PAIR (6-CONDUCTOR)		CENTIMETERS	INCHES
88P2A00A	88P4A00A	88P6A00A	00	25	9.84
88P2A0A	88P4A0A	88P6A0A	0	65	25.59
88P2A1A	88P4A1A	88P6A1A	1	70	27.56
88P2A2A	88P4A2A	88P6A2A	2	85	33.46
88P2A3A	88P4A3A	88P6A3A	3	95	37.40
88P2A4A	88P4A4A	88P6A4A	4	110	43.31
88P2A5A	88P4A5A	88P6A5A	5	125	49.21
88P2A6A	88P4A6A	88P6A6A	6	140	55.12
88P2A7A	88P4A7A	88P6A7A	7	155	61.02
88P2A8A	88P4A8A	88P6A8A	8	170	66.92
88P2A9A	88P4A9A	88P6A9A	9	185	72.83
88P2A10A	88P4A10A	88P6A10A	10	205	80.71
88P2A11A	88P4A11A	88P6A11A	11	220	86.61
88P2A12A	88P4A12A	88P6A12A	12	235	92.52
88P2A13A	88P4A13A	88P6A13A	13	230	90.55

**Note:** Codes 0 through 13 are used with the Customer Administered Terminal Move Service; code 00 is used with key system patch panels only.



Fig. 10—5-Pair Insertion Tool

- 188BB1—100 (blue, two per package)
- 188BP1—100 (purple, two per package)
- 188BY1—100 (yellow, two per package)
- 188CR1—25 (red, one per package)



Fig. 11—788C1 Tool, 5-Pair Cutoff Tool

- Insulator, Terminal, Clip F, AT-8660 (as required)
- Retainer, 88A (as required)
- Backboard, 188B1 (as required)
- ♦Cord, Patch, 88P-Type (refer to Table B)♦



Fig. 12—788D-Type Tool, Single-Pair Insertion/Cutoff

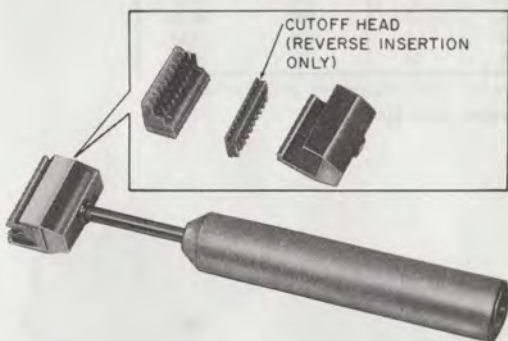

Fig. 13—788J1 Tool, Impact Insertion

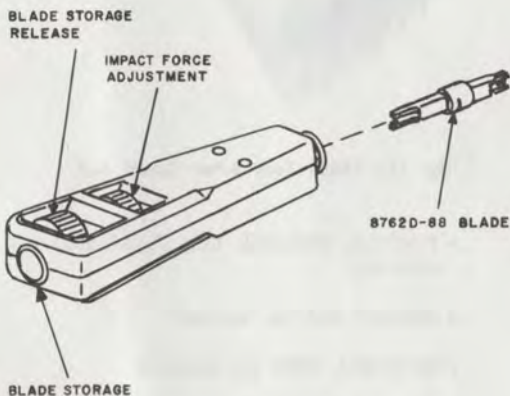

Fig. 14—D Impact Tool

- Cord, Test C, AT-8662, 4 foot or 8 foot (specify length)
- Terminal, Wire, 101B2
- Block, Test, B Key Equipment, AT-8700.

### 3. INSTALLATION

3.01 The 88-type wiring blocks are usually arranged so that the direction of expansion, if required, will be horizontal as shown in Section 518-010-101.

3.02 Wiring blocks may be added to existing blocks following the pattern established for centralized key telephone installations. Refer to Section 518-010-101.

3.03 Mount the 88-type wiring blocks with index strips horizontal on a smooth wall surface using fasteners appropriate for the type of wall surface.

3.04 Cables are considered permanent and are always placed on the index strip of the wiring block, never on top of the connecting block. Rearrangements can be made as required with cross-connect wire on top of the connecting blocks.

3.05 Cabling can enter the array of wiring blocks from either top or bottom. Fish cables behind installed wiring blocks as follows:

- (1) When station or equipment cable enters from the top, use No. 6 twine with a weight. Drop behind wiring block and use wire hook to fish through proper cable slot. Pull cable down through cable slot.
- (2) When cable enters from the bottom, drop weighted No. 6 twine through proper cable slot and down behind the wiring blocks. Pull cable up through cable slot.

3.06 Cable slots are numbered with the odd numbers on the left and the even numbers on the right, from top to bottom (Fig. 15). In the red field, only the odd number cable slots on the left side are used.

3.07 When running 25-pair station cables, leave jacket on until cable has been threaded through the proper cable slot. Start cable 1 through slot 1 to row 1, cable 2 through slot 2 to row 2, etc.



♦ TABLE C ♦

## TOOLS

ORDERING GUIDE	DESCRIPTION	REMARKS
Handle, 788A1	Tool Handle	For 788B2 or 788C1 Tools
Tool, 788B2	5-pair Insertion Tool Head	Order Handle Separately
Tool, 788C1	5-pair Cutoff Tool Head	
Tool, 788D4	1-pair Insertion/Cutoff Tool	Consists of Head and Handle
Tool, 788J1 Tool, 788H1 (MD)	5-pair Insertion Tool	Impact Type
Tool, 788K1	Lead Retention Tool	Used when removing Connecting Blocks
Handle, Tool, Impact, D	Tool Handle	Adjustable Impact Tool
Blade, 8762D-88	Single Lead Insertion or Insertion/Cutoff	For use in D Impact Tool on 88-Type Wiring Blocks*
Tool, 788M1	5-pair Tool Head	Replacement Head for 788J1 Tool

\* Blades are available for 66- or 630-type connecting blocks. For 66-type, order 8762D-66; for 630-type, order 8762D-630.

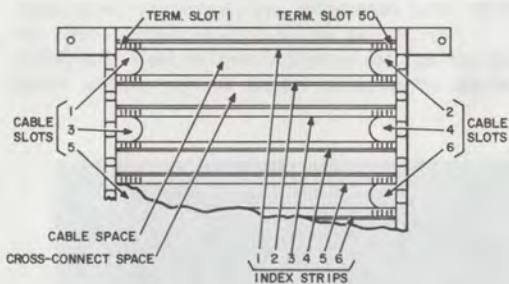

Fig. 15—Numbering Plan for 88-Type Wiring Block

**3.08** Remove the cable sheath for multiple binder cables, approximately twice the length of the wiring block, allowing the sheath end to extend under the backboard. The cable is separated into 25-pair groups with their proper identification (color binder). The 25-pair binder groups are threaded through the cable slots provided in the backboard (blue-white through cable slot number 1 to row 1, orange-white through cable slot number 2 to row 2, green-white through cable slot number 3 to row 3, brown-white through cable slot number 4 to row 4, etc (Fig. 16).

**3.09** The index strips start with number 1 at the top and continue downwards in consecutive order. The index strip slots are numbered

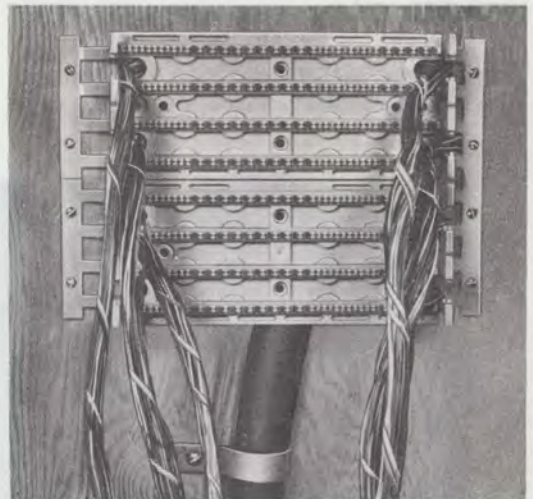

Fig. 16—200-Pair Cable in Cable Slots

consecutively from left to right with number 1 the first slot on the left and number 50 the last slot on the right. Pair number 1 would be seated in slots 1 and 2, and pair number 25 would be in slots 49 and 50.

**3.10** Terminations are made following the sequence outlined in paragraphs 3.11 through 3.24.

3.11 The conductors of a 25-pair cable or a binder group are placed in the index strip slots following the even-count color code starting with white-blue in slot 1, blue-white in slot 2, white-orange in slot 3, etc (Fig. 17). The conductors should not be taut; some slack is desirable. The high tooth on the index strip splits the conductors of a pair. Light finger pressure is sufficient to cause the conductor to be held in the index strip. Place all 25 pairs and check for split pairs, missed slots, etc.

3.12 After all pairs are placed in a pair of index strips adjacent to a cable space, the 788B2 or 788J1 insertion tool is used to seat the conductors in the index strip (Fig. 18). Start at the end of the index strip nearest the cable entrance and work across the block. Make sure conductors are bottomed in the index strip, especially when using larger gauge wire. Use only enough pressure to seat conductors. **Do not hammer on 788B2 insertion tool.**

3.13 On wiring blocks used to provide key line service multiples (red field), the conductors are placed across the five index strips, again using

a light finger pressure to place (Fig. 19). Conductors should not be tight.

3.14 Seat the conductors in the same manner described in paragraph 3.12. **When using the 788J1 tool, be sure that the blades are not exposed.**

3.15 Cut off excess wire using the 4-pair cutoff tool (Fig. 20) or the cutoff side of the 788J1 tool. Conductors should be perpendicular to index strip for ease in cutting.

**Caution: Do not use diagonal pliers or electrician scissors due to the possibility of cutting more than one wire at a time or causing shorts between conductors. Doing so may cause circuit damage to solid-state devices used in key telephone systems or PBXs.**

3.16 The conductors are electrically terminated by placing an 88-type connecting block on the wiring block using the insertion tools. **Properly align connecting block in the index strip**

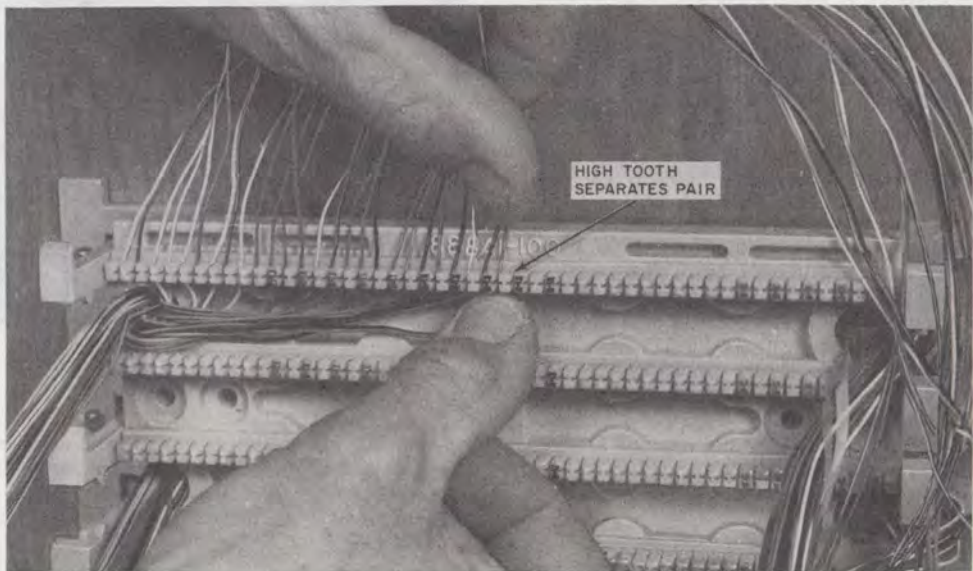

Fig. 17—Placing Conductors in Index Strip



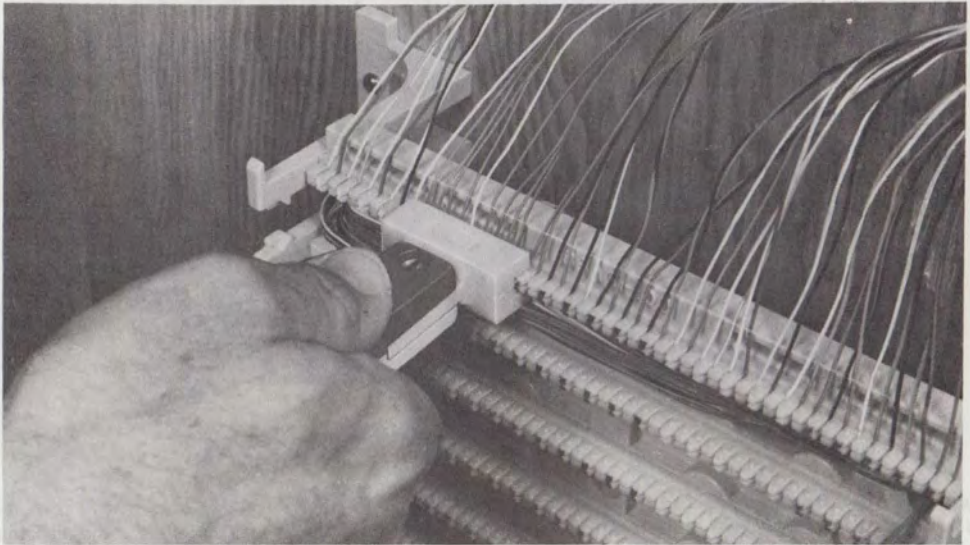

Fig. 18—Seating Conductors in Index Strip

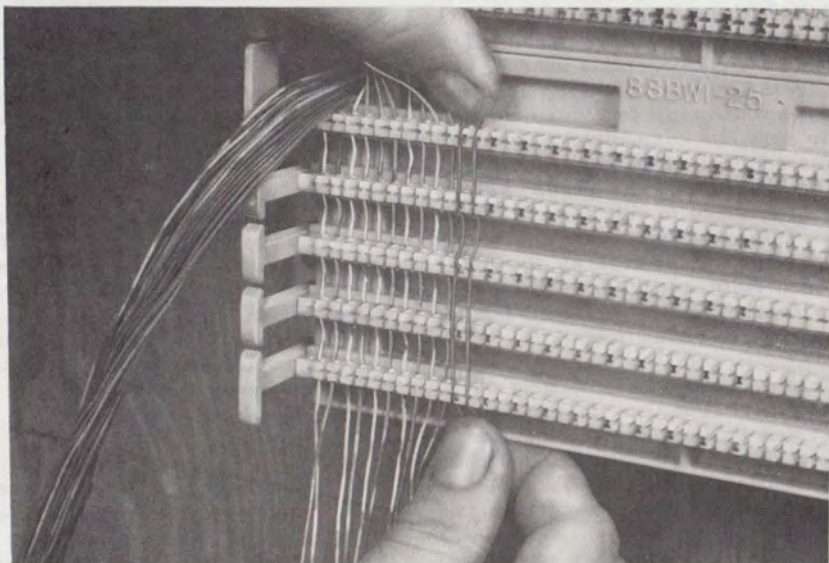

Fig. 19—Multiple Connections in Red Field

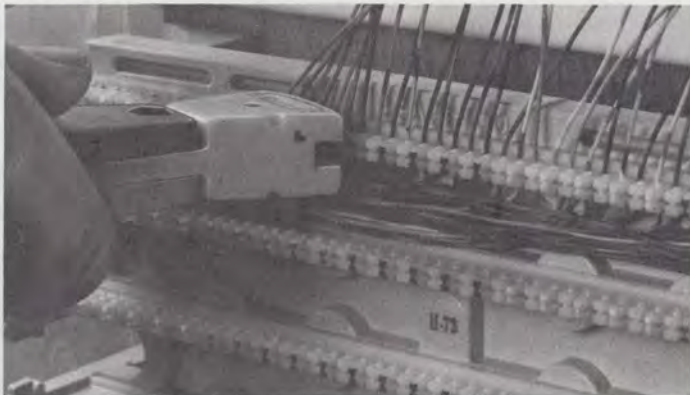

Fig. 20—Cutting Excess Wire

(Fig. 21), by hand, then seat the block with a straightforward motion (do not rock) using the 788B2 or 788J1 tool.

**Caution:** 88-type blocks are designed to prevent split pairs. Connecting blocks must be properly located on the index strip to prevent block breakage during insertion. Low teeth of the index strip engage the shallow cavities of the connecting blocks, and high teeth engage the deep cavities. To prevent damage to the conductors and to seat the connecting block with the least effort, it is imperative that proper alignment is made before applying pressure to seat the connecting block. The connecting block is properly seated when the buttons on the index strip are fully engaged by the holes in the connecting block skirt. Do not hammer on insertion tool.

3.17 The slate-white 88-type connecting blocks aid in pair identification. Place the blocks on the index strip starting with the white side up at the extreme left and alternating slate and white sides for the remainder of the strip (Fig. 22). Use the 5-pair connecting block where it is desirable to identify even-count color groups. Use the 3-pair blocks where the six leads of key system line circuits are terminated such as in the blue field. Place blocks only as required.

3.18 After all connecting blocks have been seated, snap the appropriately colored designation strip in the wiring block (Fig. 23). Mark the designation, as required, for later identification of lines or stations.

3.19 Insert the F-type, 24-gauge cross-connect wire into the connecting block slots as shown in Fig. 24. Light finger pressure is sufficient to insure retention of the wire in its proper location. **Leave 2 inches of slack in the wire for tracing and repairing.** Cross-connect wire may be routed through either fanning strip for shortest wire runs.

3.20 Using the 788D4 tool with the insertion/cutoff head extended, seat and cut off the excess wire as shown in Fig. 25. **The black side of the head must face the scrap end of the wire, which may be on the top side or the bottom side of the connecting block.** The D impact tool can also be used for this operation (using the proper blade), **but the 788C1 or 788J1 should not be used.**

3.21 When using the D impact tool to make connections to the connecting block, make sure the proper blade is being used (8762D-88) and the proper end of the blade is exposed, depending on whether or not the wire is to be cut off. The impact should be adjusted to the "LO" position.



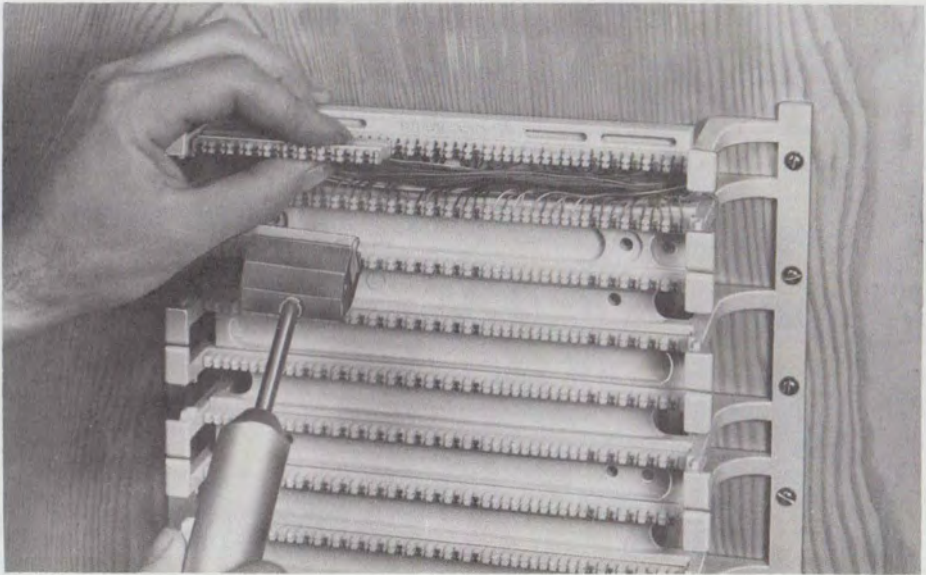

Fig. 21—Connecting Block Placed on Index Strip

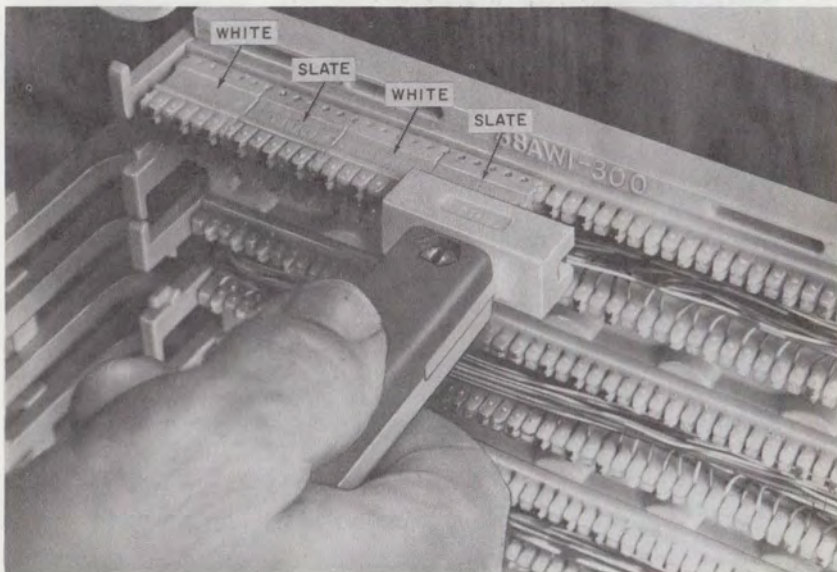

Fig. 22—Seating Connecting Block on Index Strip

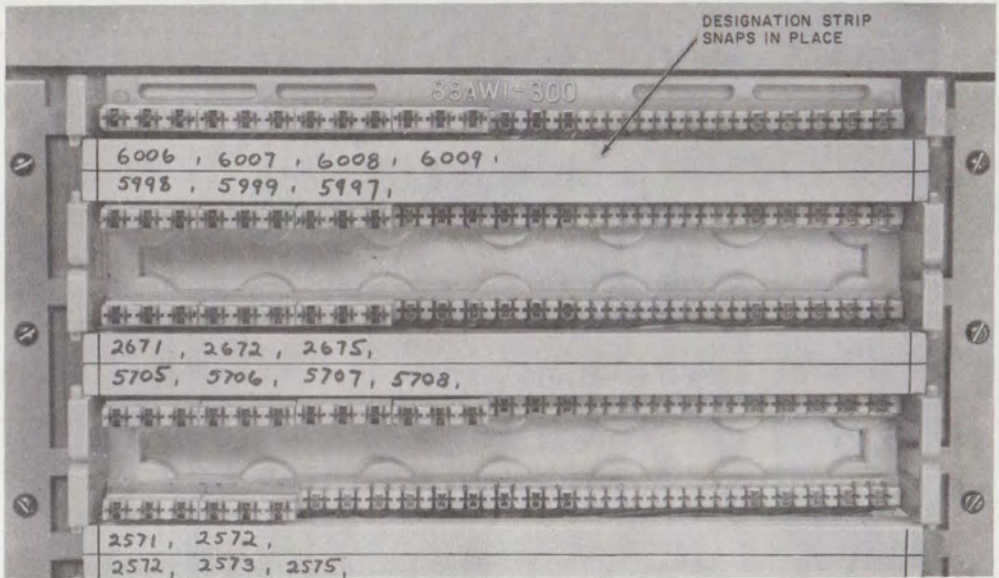

Fig. 23—Marked Designation Strips on Wiring Block

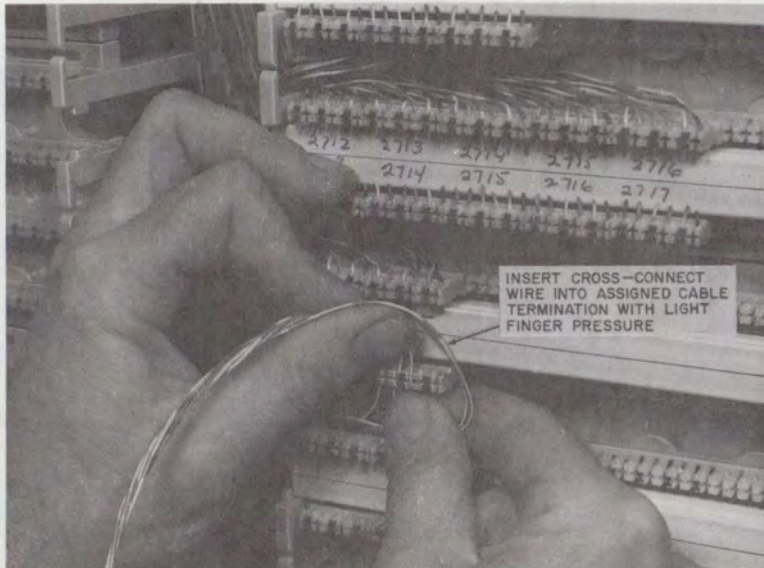
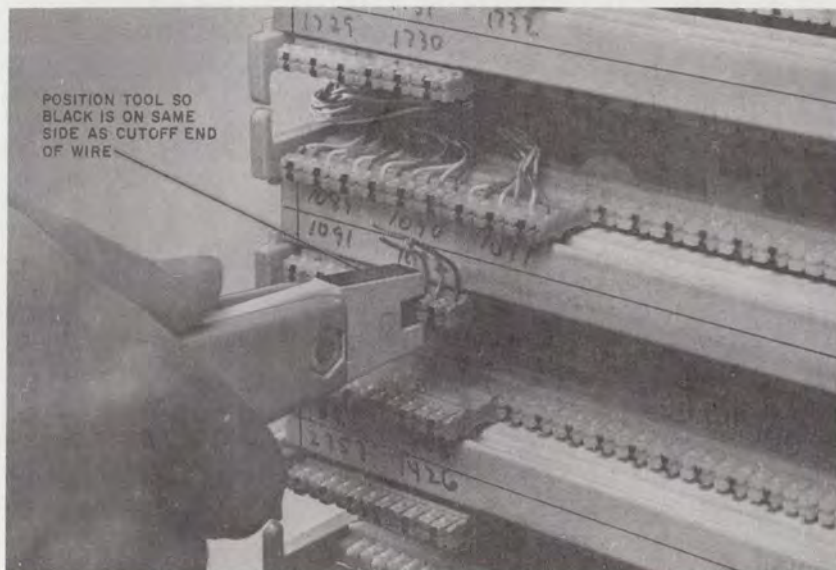

Fig. 24—Inserting Cross-Connect Wire





**Fig. 25—Terminating Cross-Connect Wire**

**3.22** Use only 24-gauge F cross-connect wire on the top of the connecting blocks. The wire may be reterminated as often as necessary as long as a new bite is taken at the connector each time it is reterminated.

**3.23** To remove a cross-connect wire, use long-nose pliers to grip the wire where it enters the connecting block (Fig. 26) and pull straight out. Remove any fragments of insulation remaining on the clip or its cavity using a KS-6320 orange stick.

**3.24** To reterminate a wire which has been removed for rearrangement or testing, cut off the old contact area, pull a small amount of slack and repeat paragraphs 3.19 and 3.20 using long-nose pliers to place wire in connecting block.

**3.25** D station wire (22 gauge) is treated as station cable and fanned into the index strip. Where D station wire is used, it should be kept to a minimum.

**3.26** Never terminate drop or block wiring on 88-type wiring blocks; always terminate on

protectors or other blocks, and cross-connect using 24-gauge wire to 88-type hardware.

**3.27** More than five multiples of a given feature can be provided, when required, using one of the following methods:

(a) Use a KS-19252,L2 (PCP) bridging adapter and the precabled wiring blocks (88BW1-25C or 88BW1-75C) to obtain ten multiples. Refer to Section 461-200-101 for information on the bridging adapter.

(b) If the need for additional multiples is known at the time the blocks are cabled, 15 multiples can be provided using an 88BW1-75 wiring block and placing the cable end in all 15 index strips.

(c) Where additions require more multiples than available, use one of the multiples to jumper to an unused or added wiring block. The jumpers should originate in the last appearance of the initial wiring block and terminate in the index strips of the new wiring block.

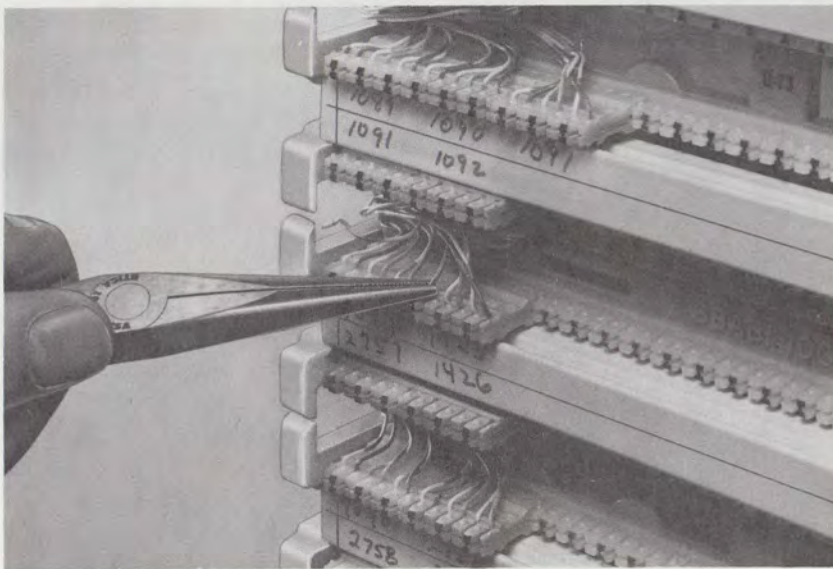

Fig. 26—Removing Cross-Connect Wire

#### 4. MAINTENANCE

4.01 Connecting blocks would normally not be removed from wiring blocks except as follows:

- (a) When the cable is being removed.
- (b) To repair a cable conductor on the wiring block.
- (c) To replace a defective connecting block.

Always tag and identify all cables and their next point of termination. **Do not remove a connecting block during routine trouble shooting. Use appropriate test tools to isolate a fault. In most cases, the fault location will not be under the connecting block.**

4.02 There is no prescribed method of repairing a damaged connecting block; the connecting block must be replaced as follows:

- (1) Tag and remove the cross-connect wires from the connecting block.

- (2) Remove the designation strip from the wiring block.

- (3) Position the blade end of the 788K1 tool at the base of the connecting block over the cable pairs to retain them in the index strip while the connecting block is being removed (Fig. 27).

- (4) Using a pair of combination or side-cutting pliers, grip the 88-type connecting block firmly in the center as shown in Fig. 27, then gently pull with a slight up-and-down motion to release the connecting block from index strip. **Do not reuse connecting block.**

- (5) If the cable conductors were pulled out of the index strip on the wiring block, replace them as follows after cutting off old contact portion of wire:

- (a) Using a pair of long-nose pliers, grip each removed conductor individually and pull to obtain slack; then reposition the conductors in their original position on the index strip (be careful not to split pairs). If enough



slack cannot be obtained to reposition the conductor in the index strips, it will be necessary to piece out the conductor (use wire having the same colored insulation and gauge; splice with Bell System or other approved connectors).

- (b) Using the 788D4 or D impact tool, seat the conductor firmly in the bottom of the index strip (Fig. 28).
- (6) Place a new 88-type connecting block as outlined in Part 3 and replace the designation strip.
- (7) Replace the tagged cross-connect wires in their original position as outlined in Part 3 after cutting off old contact part of wire.

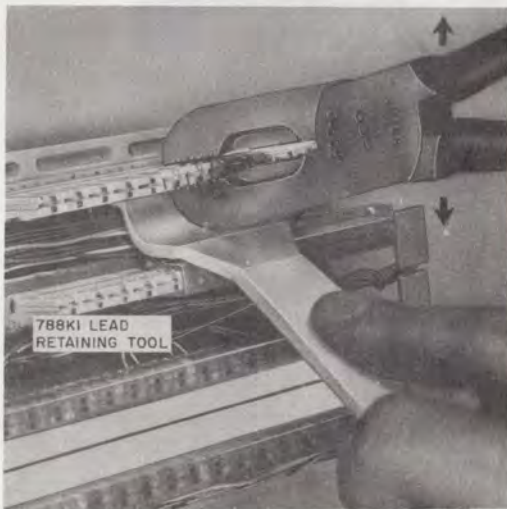

Fig. 27—788K1 Lead Retention Tool

**4.03** The B key equipment test block can be used as an aid in isolating trouble in CO/PBX lines or for testing newly installed circuits. Table C lists the various tests that can be made and the test results expected. The test block may be used on the equipment wiring blocks with or without jumpers in place. Care must be taken to align the block on the T, R, A, A1, LG, and L terminals for the line being tested.

**4.04** The lamps in the test block can be replaced as follows:

- (1) Use a straightened paper clip or equivalent to eject the lamp by inserting the clip in the small hole in the rear of the block, directly behind the lamp.
- (2) Insert the new lamp from the front, making sure the proper voltage lamp is used. The voltage of the lamp is marked directly above the ejection hole.

Replacement lamps can be obtained from Sylvania Electrical Products, Incorporated. For the 12-volt lamp (LP), use a 12ESB indicator lamp, code 31255-0. For the 48-volt lamp (T/R), use a 48ESB, code 34861-0.

**4.05** In the event it becomes necessary to replace a cable due to trouble or rearrangements, follow the procedures in the following paragraphs:

**Caution:** Do not cut a working cable. Doing so may cause system troubles or cause surge currents that can damage electronic components.

**4.06** One method of cable rearrangement requires an unused index strip as follows:

- (1) Cut off existing inside wiring cable at the blue wiring block and remove designation strip.
- (2) Replace cable, using old cable to pull in new if in duct.
- (3) Remove sheath of new cable and cut down on a vacant index strip.
- (4) Install new connecting blocks on index strip in same position as old index strip.
- (5) At the cable cutoff in (1) above, trace each 3-pair jumper back to its origin on the red wiring block.
- (6) Remove the old jumpers, one at a time, and run new jumpers to the connecting blocks mounted on the new index strip.
- (7) Replace designation strip, marking as required.

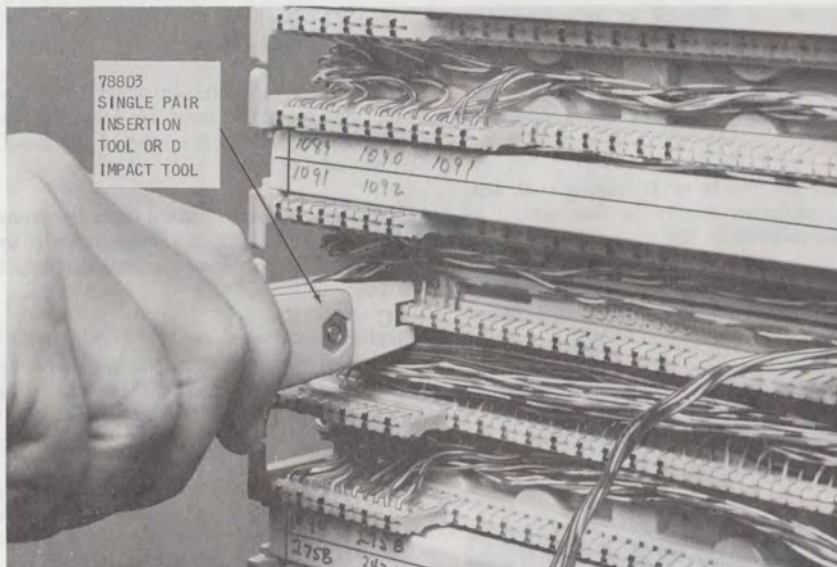

Fig. 28—Seating Conductors With Single-Pair Insertion Tool

- (8) Remove connecting blocks and IW cable from old index strip. This strip can be used in future rearrangements.
- 4.07** An alternate method of cable rearrangement uses the existing index strip as follows:
- (1) Cut off the IW cable at the blue wiring block and remove the designation strip.
  - (2) Replace cable, using old cable to pull in new cable if in duct.
  - (3) Remove each 3-pair jumper from the connecting blocks, tagging each with its location.
  - (4) Remove the connecting blocks and the stub ends of the cutoff cable.
  - (5) Cut down the new cable on the index strip and install new connecting blocks in the same positions, as required.
  - (6) Rerminate jumpers in proper position on connecting blocks, making sure to cut off old contact area.
  - (7) Replace designation strip, re-marking if required.





TABLE D

## B KEY EQUIPMENT TEST BLOCK OPERATION

SWITCH POSITIONS		LAMP INDICATIONS		TEST RESULTS
H	TST-TLK	T/R	LP	
Normal	Test	On	On	Normal—KTU OK, CO/PBX line OK
		Off	On	KTU OK—CO/PBX line open or short
		On	Off	KTU defective (A lead)—CO/PBX line OK
		Off	Off	KTU defective, missing or miswired
Depressed	Test	Off	Wink	Normal—if key system is wired for wink-on-hold
		Off	Steady	Station off-hook or short on line (Note 1)
		On	Off	KTU defective or faulty power supply
		Off	Off	KTU defective, missing or miswired
Normal	Talk	Off	On	Normal (Note 2)
		Off	Off	KTU defective, missing or miswired
Depressed	Talk	Off	Off	Normal
		Off	On	Station off-hook or short on line

*Note 1:* Normal if key system is wired for steady lamp on hold.

*Note 2:* If CO/PBX line is connected, it should be possible to dial out using hand test set connected to terminals.