

INTERCONNECTING DEVICES COMMON EQUIPMENT

75A CONTROL UNIT

1. GENERAL

1.01 This section provides identification, installation, operation, and maintenance information for the 75A control unit used with the 604B panel to provide data transmission capabilities for various voice connecting arrangements (VCA).

1.02 The 75A control unit has been designed to work with the 101B and 102B voice type interconnecting units (IUs).

1.03 Refer to the section describing the specific VCA for the particular IU to use and for the VCA installation information.

1.04 This issue of the section is based on the following drawings:

CD/SD-1E246-01 Issue 1—75A Control Unit

If this section is to be used with equipment or apparatus reflecting later issue(s) of the drawing(s), reference should be made to the SDs and CDs to determine the extent of the changes and the manner in which the section may be affected.

2. IDENTIFICATION

PURPOSE

- To protect the network by linearly attenuating excessive voice and data signals from customer-provided (CP) PBX by means of automatic level control (ALC).

ORDERING GUIDE

- Unit, Control, 75A (one per six lines, Fig. 1)

DESIGN FEATURES

75A Control Unit

- Components mounted on epoxy coated 8-inch 40-pin board.

- Limits excessive voice or data signals.
- Consists of six identical ALC circuits. Each ALC circuit is capable of automatically controlling the level of signals transmitted through its associated IU to limit the 3-second average power arriving at the CO to -12 dBm (at $+1$ TLP).
- Designed to mount in a 604B panel.
- Contains adjustable potentiometers for setting each ALC circuit to limit at any level between -14 and -4 dBm.
- Contains two voltage regulators to convert -24 volt input dc voltage to a regulated -12 volts dc.
- Operating temperature range of 20°F to 140°F .
- Requires a dc current input of 0.360 ampere (maximum) at 26 volts dc (maximum) at full load (only 0.1 ampere on standby).

3. INSTALLATION

3.01 The 75A control unit is plugged into position 13 of the 604B panel to furnish ALC to IUs in positions 1 through 6 and/or plugged into position 14 for positions 7 through 12. Only trunks equipped for data transmission capabilities should be assigned to these positions. Since the 604B panel is prewired for the 75A, all connections are made when it is plugged into the panel.



The electrical design of the 75A control unit protects it from voltage surges and it may be installed or removed without disturbing service to the associated IUs.

3.02 When installing the 75A control unit, raise the designation strip retainer bar and position the board in the guide grooves of the 604B panel. Slide the board in until the unit is properly seated.

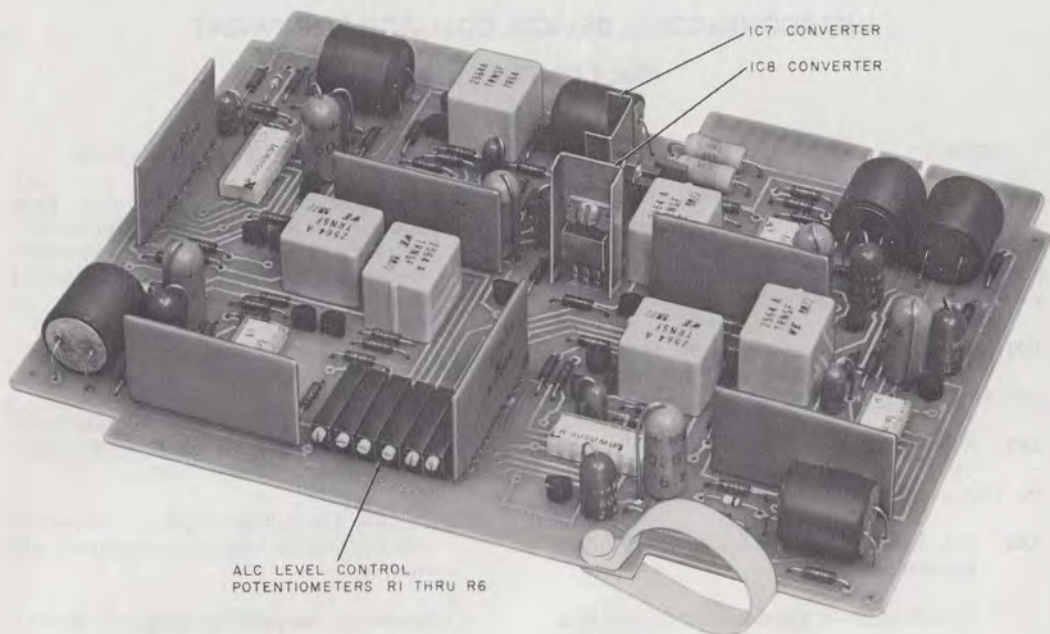

Fig. 1—75A Control Unit

in the connectors. Lower the designation strip retainer bar to hold the circuit boards securely in place.

3.03 After installation adjust the limiting level threshold by setting the six level control potentiometers as described in 5.03 through 5.10.

4. OPERATION (Fig. 2 and 3)

4.01 The 75A control unit consists of six identical ALC circuits, each connected across the tip and ring of an IU to protect Bell System equipment from excessive signal power. This protection is required for data transmission.

4.02 The ALC circuit monitors the CP data/voice voltages applied to the IU. If the power exceeds a preset level, the ALC circuit will present a resistance shunt across the transmission circuit in the IU to linearly attenuate the signal to the preset level.

4.03 Voice or data signals present in the IU are applied to transformer T1 in the 75A control unit (Fig. 3). The output of T1 is level adjusted, amplified, and ac coupled to the piecewise linear squaring circuit. The squaring circuit output is integrated to produce a dc voltage proportional to the 3-second average power of the signal passing through the IU. When this voltage exceeds the preset threshold voltage of the ALC circuit, the differential amplifier will drive current through the optical coupler (OC1) lamp, which illuminates the photoconductor (resistor) in OC1. Illumination causes the resistance of the photoconductor to decrease and shunt excess signal power away from the IU so as to hold the signal level at the IU constant at the preset level.

4.04 The level adjusting potentiometers R1 through R6 are set to limit the customer signals to a level determined by the loop or trunk loss and impedance.

4.05 Below the threshold level, the ALC circuit loads the transmitted signal by approximately

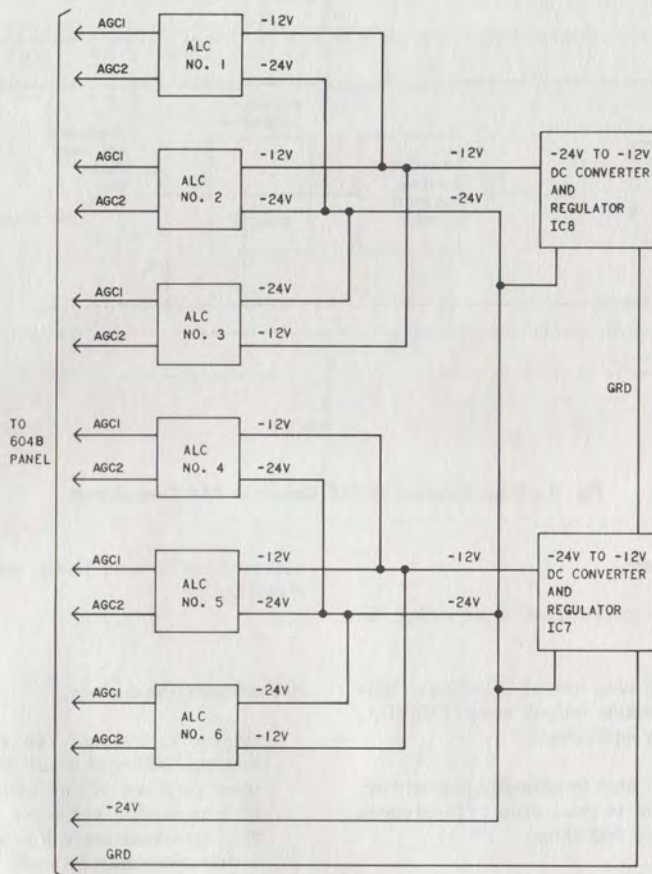

Fig. 2—Block Diagram of 75A Control Unit

0.1 dB. Complete dc isolation between the ALC circuit and its associated IU and customer-provided equipment (CPE) is provided by transformer T1 and optical coupler OC1.

4.06 The six identical ALC circuits in the 75A control unit are powered by the two voltage regulators IC7 and IC8 (Fig. 4). Each voltage regulator supplies three ALC circuits. The two regulators convert the -24 volts dc supplied to the 75A into regulated -12 volt dc. Each voltage regulator supplies 180ma (60ma for each ALC) at 12.0 ± 0.5 volt dc. The minimum current drain

for the 75A with all six circuits in the idle condition is 50ma. Each circuit when in use draws 60ma for a total maximum current drain of 360ma.

5. MAINTENANCE (Fig. 5 and 6)

5.01 The 75A control unit may be used on trunks with losses up to 10 dB. The control unit may be adjusted to prevent the power arriving at the CO over a 3-second average from exceeding -12 dBm. The level adjusting controls provide a range of -14 dBm to -4 dBm.

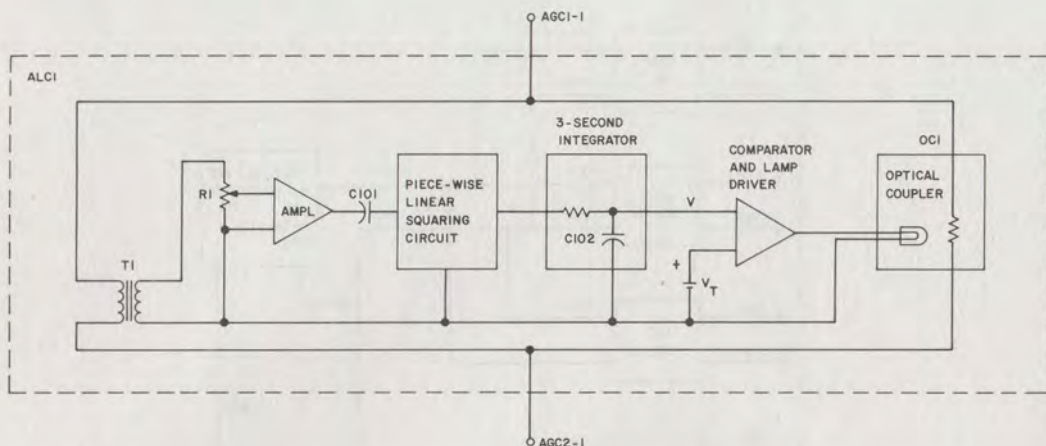

Fig. 3—Block Diagram of ALC Circuits in 75A Control Unit

Equipment Required

5.02 The following are required in adjusting the ALC circuits:

- Oscillator, 600 ohm output impedance, 1000 Hz with adjustable output level (TMS 21A, KS-19353L4 or equivalent)
- Voltmeter, AC high impedance, greater than 50K, calibrated to read dBm. (Referenced to 1 milliwatt at 600 ohms)
- Resistor, 600 ohms 1/4 watt, 1 percent
- Hand test set, 1013A or equivalent

Preparation

5.03 Disconnect the CPE for all lines under test by removing the B bridging clips at the 66M1-50 interface connecting block. Make all test connections to the CT and CR terminals on the Telephone Company side of the interface connecting block. Refer to the section for the particular voice connecting arrangement in use to determine what straps may be necessary to cause the IU to operate and cut through the transmission path. Turn all six level adjusting controls on the 75A 20 turns counterclockwise. (The control is a 17 turn potentiometer without mechanical stops; the shaft

will continue to turn freely after resistance limit is reached.)

Adjustment Procedure

Note: In 5.04 and 5.06, a voltmeter with an internal 600-ohm input termination may be used in place of the 600-ohm resistor and high-impedance voltmeter. In 5.07 and 5.09, the high-impedance voltmeter (without 600-ohm termination) must be used.

5.04 Measure the received power (P_R) on the line as follows:

- (1) Connect test equipment as shown in Fig. 6A.
- (2) Using the 1013A hand test set or equivalent, place a call on the line under test to the milliwatt supply (1000 Hz test tone) at the serving CO. Terminate the CT and CR terminals to the IU in the 600-ohm resistor.
- (3) Measure the received power across the resistor in dBm and record.
- (4) Repeat for all lines under test.
- (5) Disconnect from milliwatt supply.

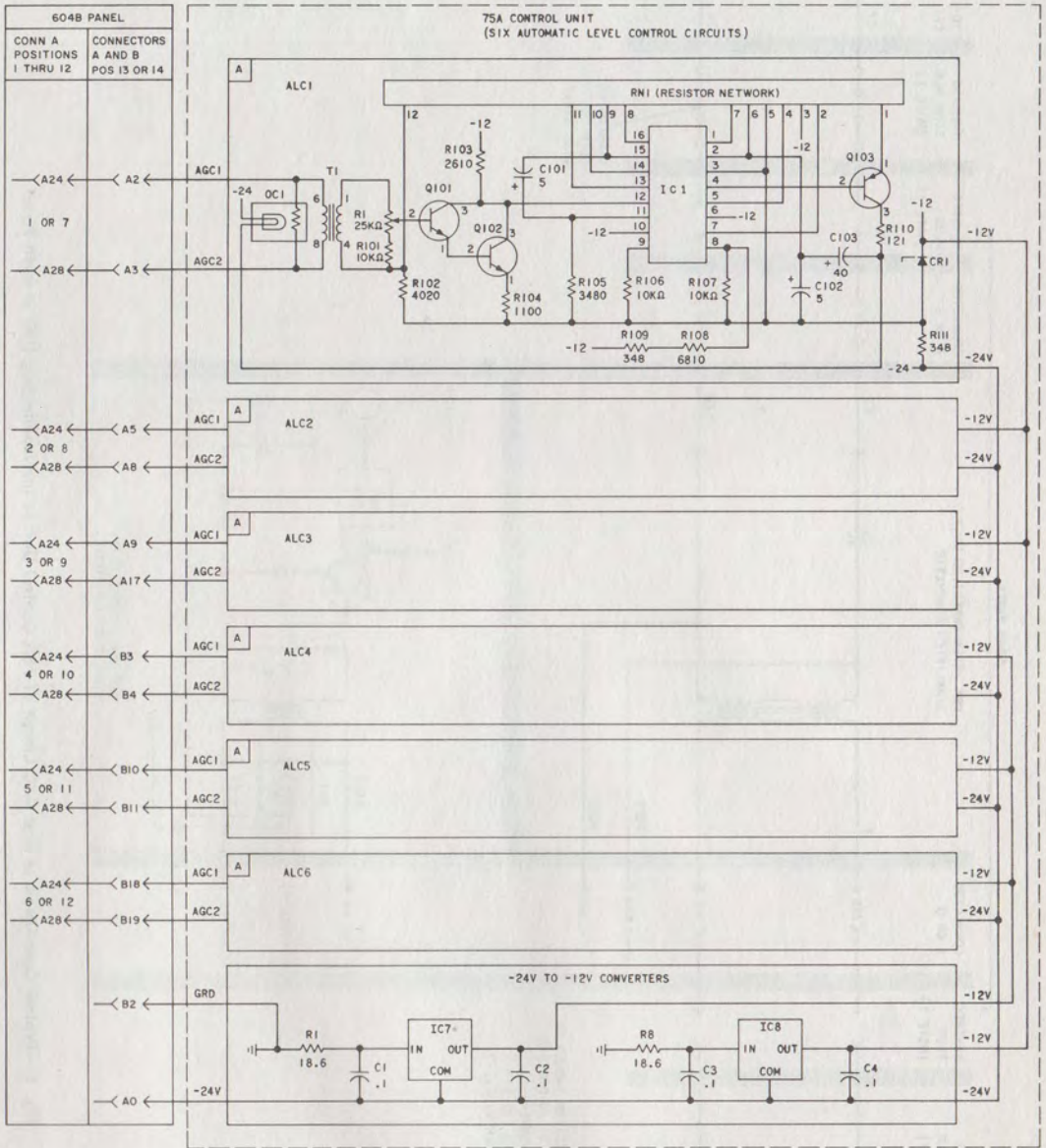

Fig. 4—Simplified Schematic—75A Control Unit

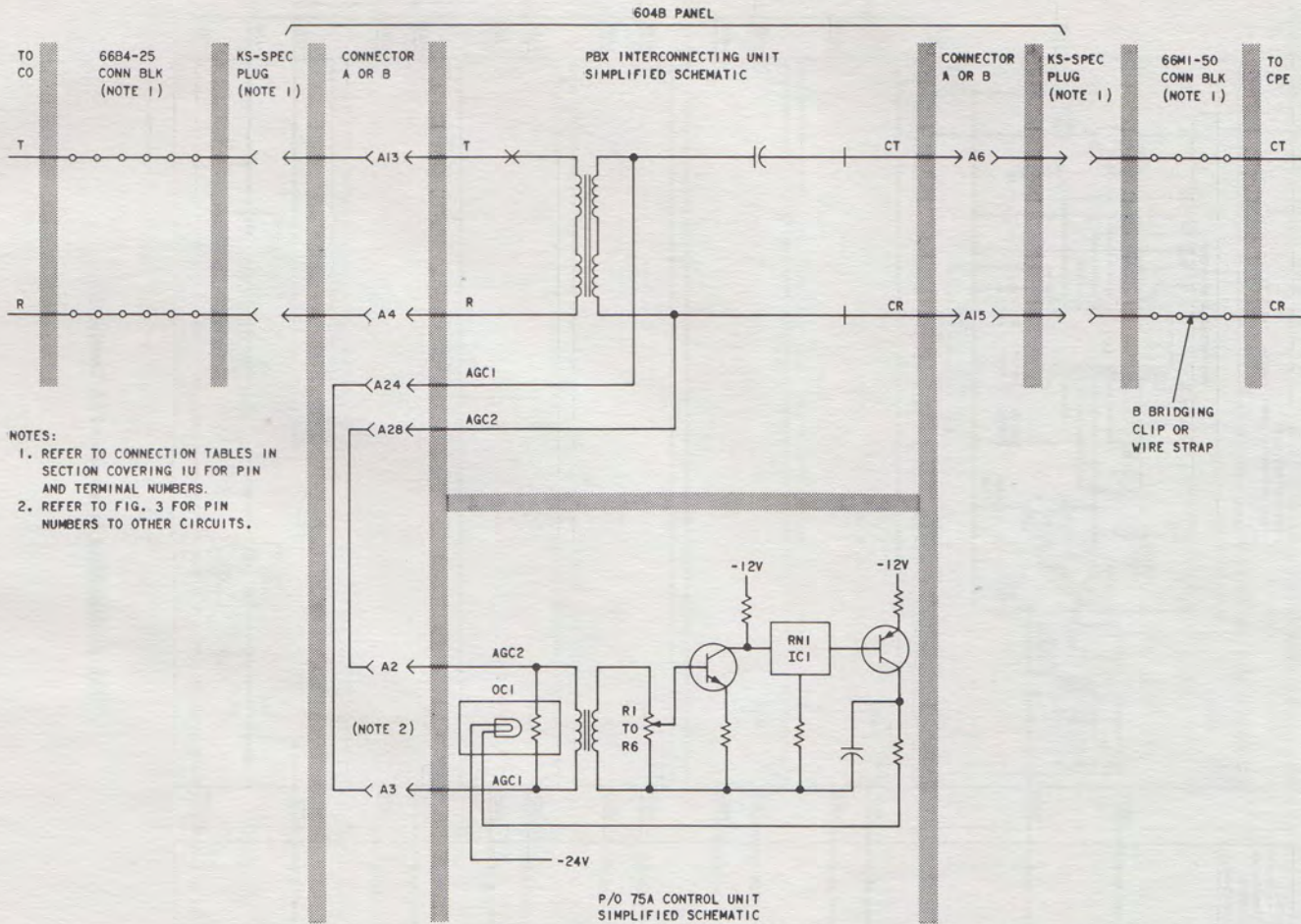
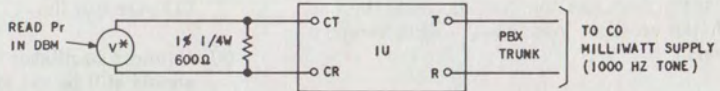
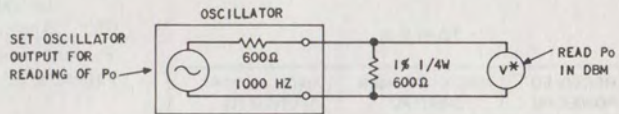

Fig. 5—Typical Connection of First ALC Circuit of 75A Control Unit to Interconnecting Unit in 604B Panel



* HIGH IMPEDANCE AC VOLTMETER (VOLTMETER WITH INTERNAL 600Ω INPUT TERMINATION MAY BE USED IN PLACE OF RESISTOR AND HIGH IMPEDANCE VOLTMETER)

A. MEASURE RECEIVED POWER



* HIGH IMPEDANCE AC VOLTMETER (VOLTMETER WITH INTERNAL 600Ω INPUT TERMINATION MAY BE USED IN PLACE OF RESISTOR AND HIGH IMPEDANCE VOLTMETER).

B. SET OSCILLATOR OUTPUT POWER

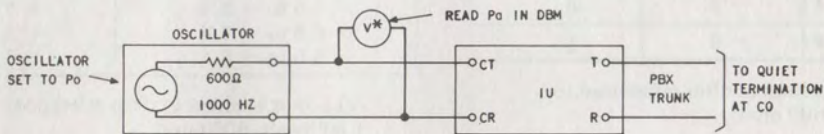

* HIGH IMPEDANCE AC VOLTMETER (NO 600Ω TERMINATION)

C. MEASURE APPARENT POWER

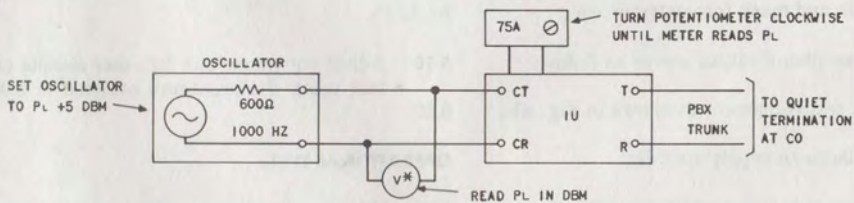

* HIGH IMPEDANCE AC VOLTMETER (NO 600Ω TERMINATION).

D. ADJUST LEVEL CONTROL ON 75A

Fig. 6—Typical 75A Set Up Procedure

Note: If several lines are being adjusted at the same time, use the reading from the line with the smallest loss (least -dBm received power).

5.05 For purposes of illustration, assume the P_R reading was -3 dBm.

- (1) Using this reading, refer to Table A to find the test oscillator power (P_o) and the maximum allowable power from the customer (P_c). Using the assumed reading of -3 dBm, P_o is -8 dBm and P_c is -10 dBm.

TABLE A

RECEIVED POWER P_R	MAX CUSTOMER POWER P_C	OSCILLATOR POWER P_O
-1.5 to -2.4	-11	-8
-2.5 to -3.4	-10	-8
-3.5 to -4.4	-9	-8
-4.5 to -5.4	-8	-8
-5.5 to -6.4	-7	-7
-6.5 to -7.4	-6	-6
-7.5 to -8.4	-5	-5

All power readings in dBm referenced to 1 milliwatt, 600 ohms.

- (2) P_c is the maximum allowable power that the customer's signal source should deliver into a 600-ohm resistive load and must be posted at the interface block for the customer's use. (Attach a tag to interface connecting block on customer side and mark for customer use.)

5.06 Set the oscillator output power as follows:

- (1) Connect test equipment as shown in Fig. 6B.
- (2) Set oscillator to supply 1000-Hz.
- (3) Adjust oscillator output to read P_o on voltmeter (-8 dBm in example given).

5.07 Measure apparent power as follows:

- (1) Connect test equipment as shown in Fig. 6C except do not connect to CR and CT.

- (2) Place call to quiet termination at serving CO over test line.
- (3) Connect oscillator to CR and CT (output should still be set at P_o) and read apparent power (P_A) on voltmeter.

Note: The apparent power may be larger or smaller than the oscillator power into the 600 ohm resistor, depending on the line impedance characteristics.

5.08 Using reading of P_A obtained above, refer to Table B to determine power level setting (P_L). Again for purposes of illustration, assume P_A was found to be -11 dBm. Table B then indicates that P_L should be -10 dBm.

TABLE B

APPARENT POWER P_A	75A LEVEL SETTING P_L
-10.5 to -11.4	-10
-9.5 to -10.4	-9
-8.5 to -9.4	-8
-7.5 to -8.4	-7
-6.5 to -7.4	-6
-5.5 to -6.4	-5

All power readings in dBm referenced to 1 milliwatt, 600 ohms.

5.09 Connect test equipment as shown in Fig. 6D, increase the oscillator output, measured on the voltmeter, several dBm above the level of P_L (-10 dBm is example) then turn potentiometer on 75A control unit clockwise until voltmeter again reads P_L .

5.10 Adjust potentiometers for other circuits under test using the procedure outlined in 5.04 to 5.09.

OPERATIONAL TEST

5.11 When trouble is suspected in the 75A control unit, a quick operational test may be performed by opening the suspected circuit at the interface connecting block. Connect an oscillator and voltmeter to the CT and CR terminals to the IU. Slowly increase oscillator output power from about -15 dBm to 0 dBm. The voltmeter reading

should slowly increase up to a point approximately equal to the P_c value and remain there as the oscillator output is increased to 0 dBm. This would indicate that the ALC circuit is working properly. Repeat this procedure for the other five ALC circuits in the 75A control unit.

5.12 If trouble is suspected in the 75A control unit, replace it with a new unit and adjust the six level adjusting controls according to the set up procedures given in 5.03 to 5.10 above.

5.13 If trouble is not indicated to be in the 75A control unit, refer to the section covering the IUs in use for further tests.

5.14 If the tests are satisfactory, remove all test connections and replace the B bridging clips (or wire straps) on the 66M1-50 interface connecting block.



Do not attempt any tests or repairs to the customer-provided equipment.

5.15 When in the repairman's judgment the trouble is located in the CPE, the Repair Service Bureau should be notified so that proper Maintenance of Service Charge billing can be initiated as outlined in Section 601-101-312 entitled Maintenance of Service Charge on Service With Customer-Provided Equipment (CPE).

6. CONNECTIONS

6.01 All necessary connections are provided by the internal wiring of the 604B panel when a 75A control unit is plugged into position 13 or 14.