

## VOICE CONNECTING ARRANGEMENT STC KS-20721 STATION COUPLER

### 1. GENERAL

**1.01** This section provides identification, installation, operation, maintenance and connection information for the KS-20721, List 1 and KS-20721, List 4 general purpose station couplers when used in Voice Connecting Arrangement (VCA) STC. (Suffixes QX and VX have been deleted.)

**1.02** This section is reissued to:

- Revise conditions for use of List 11 pulse corrector
- Add information on noise pickup (6.04)
- Remove key system leads from Fig. 7 and 9; delete key system reference from note under Table A.
- Add lead designations to Fig. 8.

**1.03** The customer should be informed by the manufacturer or supplier of the equipment of the proper VCA to be used with his equipment.

**1.04** If the customer wants a copy of the Technical Reference which covers the above VCA, the customer should contact the local Telephone Company Business Office or the Marketing Representative.

**1.05 Lettered Steps:** A letter a, b, c, etc, added to a step number in Part 5 of this section indicates an action which may or may not be required depending on local conditions. The condition under which a lettered step or a series of lettered steps should be made is given in the ACTION column, and all steps governed by the same condition are designated by the same letter within a test. Where a condition does not apply, all steps designated by that letter should be omitted.

**1.06** The KS-20721 station coupler is a general purpose station coupler used with several voice connecting arrangements. All features and options are not shown; only those applying to STC are shown.

**1.07 Voice Connecting Arrangement STC:** This connecting arrangement is intended to be used to connect customer-provided equipment (CPE), typically telephone sets to Bell System central office (CO) lines. The arrangement provides 20-Hz ringing and talk battery over a 3-wire interface. This VCA does not provide bridged ringing and may not be directly compatible with customer-provided (CP) line circuits which are similar in design to the 400D key telephone units. Modifications, if required, should be made to CPE by the customer.

**1.08** The KS-20721, List 15 test set may be used to test the station coupler, or apparatus shown in Fig. 10 may be used.

**1.09** This issue of the section is based on the following drawing:

SD-69903-01, Issue 5B—KS-20721 Station Coupler

If this section is to be used with equipment or apparatus reflecting later issue(s) of the drawing(s), reference should be made to the SDs and CDs to determine the extent of the changes and the manner in which the section may be affected.

### 2. IDENTIFICATION

#### PURPOSE

- To provide facilities for connecting various types of CPE to the telephone line
- To limit excessive levels from CPE and to provide protection for personnel and facilities against hazardous voltages.

#### APPLICATION

- Provides for the connection of CP main or extension telephones to a CO.

#### ORDERING GUIDE

- Coupler, Station, KS-20721, L4 (Fig. 1)

The List 4 consists of the following items which may be ordered separately and assembled in the field:

- Coupler, Station, KS-20721, L1 (Fig. 1 and 2)
- Assembly, Hinge, KS-20721, L10 (Fig. 3)
- Supply, Ring, KS-20721, L14 (Fig. 5)
- Corrector, Pulse, KS-20721, L11 (Fig. 4)
- Set, Test, KS-20721, L15 (Fig. 6)
- Tool, KS-19192, L1 (not required on later model units which have slotted screws)
- Transformer, 2012B (One per coupler)
- Unit, Power, 19-type (or equivalent when required for multiple couplers, see 6.03).

#### DESIGN FEATURES

**2.01** The VCA STC provides the following features:

- DC isolation and high-voltage surge protection
- 20-Hz ringing detection
- 20-Hz ringing signal to customer equipment
- Network control signaling (off-hook, dial pulse, tone address signaling, and disconnect)
- Talk battery to customer equipment
- 2-way voice transmission
- AC or DC powered.

**2.02** The KS-20721, List 4 station coupler (Fig. 1) consists of a KS-20721, List 1 station coupler with a KS-20721, List 10 hinge assembly and a KS-20721, List 14 ring supply, factory installed.

**2.03** The KS-20721, List 1 station coupler (Fig. 2) is the basic unit, designed to be field equipped with a KS-20721, List 10 hinge assembly for mounting any combination of the optional circuit packs (Fig. 3). The circuit packs are equipped with lead connectors for easy installation.

**2.04** The KS-20721, List 11 pulse corrector is not required for initial installations. It shall be used only after it has been determined that the dial pulses received from the CPE meet all requirements specified in the Technical Reference and pulsing problems still exist. It should not be used to correct poor customer pulses. When adding the List 11 pulse corrector (Fig. 4) to the List 1 coupler, remove wiring option Q and provide option V as shown in Table A.

**2.05** The List 14 ring supply (Fig. 5) provides a high voltage 20-Hz ringing signal to leads RU1 and CR to operate up to three CP ringers (C4 type or equivalent). The circuit consists of a dc to dc inverter supply and a relay driver. The inverter changes the 21V dc input to approximately 120V dc output. When ringing is present, the RU relay operates at a 20-Hz rate to alternate the polarity of the 120V dc output to provide the ringing signal. The List 14 ring supply is added to the List 1 coupler by providing option X as shown in Table A.

**2.06** The KS-20721, List 15 test set plugs into the connector on the station coupler and is used with a 1013A hand test set (or equivalent) to check the operation of the coupler with the CPE disconnected (Fig. 6).

#### 3. INSTALLATION—KS-20721, LISTS 1 AND 4 STATION COUPLERS (Refer to Tables A and B)

**3.01** The installer should provide the necessary internal wiring options that are specified for VCA STC using Table A. The features provided by the various options are explained in Table B. The KS-20721 station coupler is designed for wall or shelf mounting, weighs 4 lbs, measures approximately 9 inches square by 3 inches deep, and has a metal base with plastic cover. (Cover screws require KS-19192, List 1 tool for early models, screwdriver for later models, and may be changed by the installer.)



*If there is no telephone set on the line, use a ringer simulator (to prevent line testing open). Use an AA-1A ringer simulator. If not available, an EIC ringer installed and silenced as described in Section 501-251-100, 3.05, may be used.*

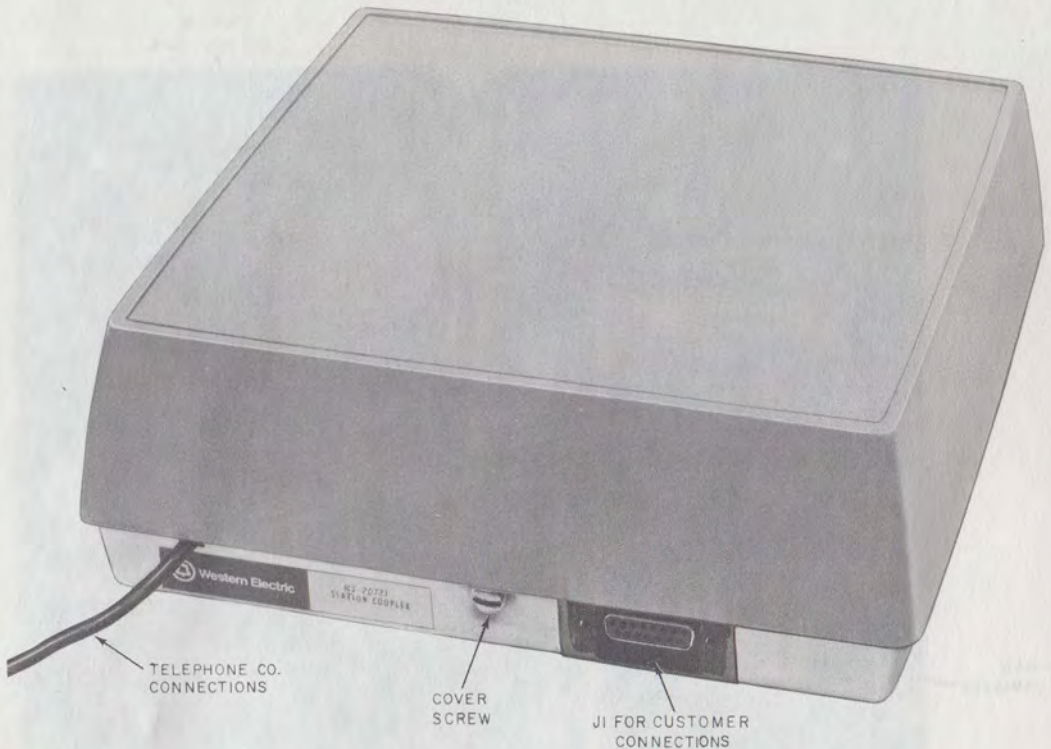

Fig. 1—KS-20721, List 1 or List 4 Station Coupler

**3.02** A 15-pin connector (J1, Fig. 1) is located on the base of the unit to connect the transmission path and control leads to the CPE. The mating Cinch Manufacturing Co. or ITT-Cannon Electric Plug No. DA-19603-403 with Hood No. DA-51225-1 is customer-provided. Screw terminals on the left side of the printed circuit board provide connections to the CO line, Telephone Company-provided telephone set, and 2012B power transformer (or power supply). Flexible jumper leads with connectors provide for installation options.

**3.03** When using an associated Telephone Company telephone set, locate station coupler within 5 feet of the telephone set, if practical, and connect telephone set mounting cord directly to station coupler; otherwise, interconnect set and station coupler using D station wire. Secure telephone set mounting cord or D station wire to clamp at lower left corner of station coupler. All Telephone

Company-provided station sets on the line must be connected to the T and R terminal on the coupler.

**3.04** The location and method of installing the station coupler shall be consistent with standard practices. The station coupler should be located in a place mutually agreeable to the customer and Telephone Company and readily accessible for maintenance and convenient for customer connection. When mounting the coupler with screws do not overtighten and bend the base. Mount the unit close to a 115V ac convenience outlet not under control of a wall switch when power is provided by a 2012B transformer or 19-type power unit.



*Complete all installation work before applying power or connecting the CPE.*



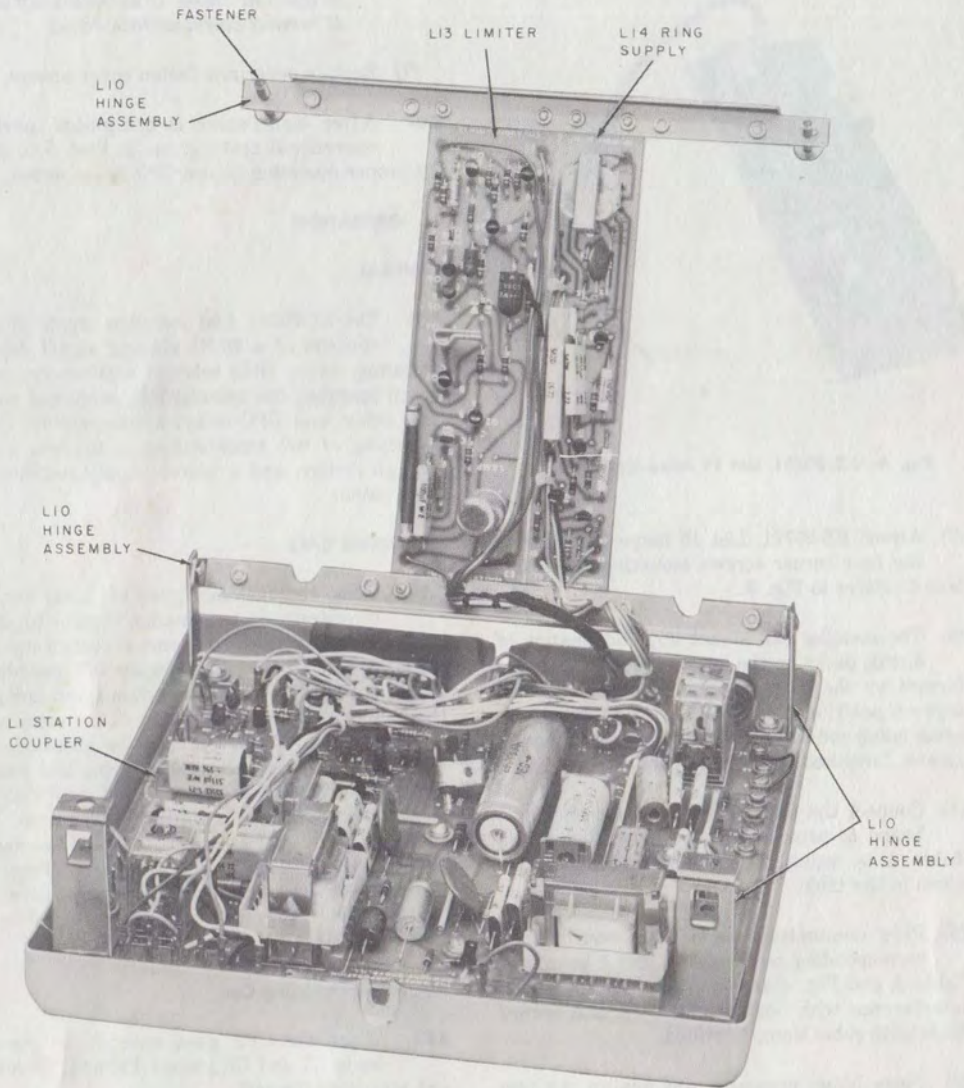

Fig. 3—KS-20721 Station Coupler Showing Optional Circuit Packs

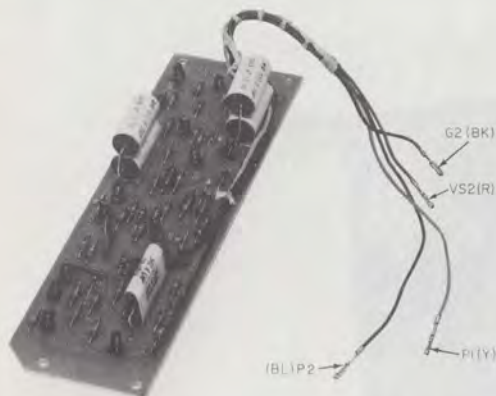

Fig. 4—KS-20721, List 11 Pulse Corrector

- (2) Attach KS-20721, List 10 hinge assembly to the four corner screws mounting the List 1 board. Refer to Fig. 3.
- (3) The installer can mount any combination of circuit packs on the internal mounting frame formed by the hinge assembly. Place board in correct position on frame (refer to Fig. 3 or cover label) and secure with four corner mounting screws furnished with circuit pack.
- (4) Connect the flexible jumper leads on List 1 board to provide the options called for in Table A by using the connecting information given in the table.
- (5) Plug connecting leads from boards into corresponding terminals on List 1 board per Table A and Fig. 4 and 5. Dress leads to avoid interference with boards and cover and secure leads with cable clamp provided.
- (6) Close hinge assembly and fasten the two top corner fasteners.



*Early models had special quarter-turn fasteners. Current models have conventional captive screws which fasten clockwise and release when turned counterclockwise. On early models, turn fasteners clockwise only*

*to open or close. (Fastener may break if turned counterclockwise.)*

- (7) Replace cover and fasten cover screws.

**3.07** After installation is completed, perform operational tests given in Part 5 to check for proper operation before CPE is connected.

#### 4. OPERATION

##### GENERAL

**4.01** The KS-20721, List 1 station coupler (Fig. 7) consists of a 20-Hz ringing signal detector operating ringup (RU) relay; a supervisory control circuit operating line transfer (TR) relay, dial pulsing (PR) relay, and CPC relay; a transmission circuit consisting of two transformers in tandem, a peak voltage limiter, and a power supply rectifier and filter circuit.

##### OUTGOING CALL

**4.02** When the customer goes off-hook, the CPE provides a dc termination (option S) across leads CT and CR to permit network control signaling (off-hook and dialing). The coupler will immediately seize the telephone line (P option) and complete the 2-way transmission path. The termination between leads CT and CR must be maintained for the duration of the call except during dial pulsing. The CPE maintains the termination until dial tone is returned before transmitting dial pulses. The coupler repeats dial pulses or tone address signals through PR relay to the CO line. Two-way transmission is provided during line seizure; dial tone and call progress tones are returned to the CPE.

##### Disconnect Outgoing Call

**4.03** When the CPE goes on-hook by opening leads CT and CR, relays PR and TR release and terminate the call.

##### INCOMING CALL

**4.04** When 20-Hz ringing is detected by the ring detector circuit, relay RU will pulse (following ringing signal) to apply ringing voltage to the CPE. The List 14 ring supply is used with option X to apply a high voltage 20-Hz ringing signal between leads CR and RU1 to the CPE to operate up to

TABLE A  
WIRING OPTIONS FOR FIELD INSTALLATION

OPTION LEADS		FROM† TERMINALS ON L1	TO TERMINALS ON L1					
LOC	COLOR		OPTIONS					
			P	Q‡	S	V‡	X§	Z¶
LEADS ON L1 BOARD	G	N						N
	BL	K1			K3			
	S	K4			K6			
	O	F10					F6	
	BR	F6					F9	
	V	F4					F10	
	BK	F5					F5	
	Y	P2		P2		P3		
	S*	F8					F8	F8
	BL*	F7					F4	
	W	M	G5					
CIRCUIT PACKS	R					VS2	VF4	
	BK					G2	G4	
	Y					P1	F1	
	BL					P2	F2	
	G						F14	
	S						F12	
	O						F13	

\*These leads originate from J1 connector.

†Leads stored on these terminals when not in use.

‡Remove Q option before installing V option (Telephone Company option).

§Strap screw terminals A and A1.

¶Option Z is factory wired.

three CP ringers (C4-type or equivalent, bridged ringing is not provided). The ring detector circuit requires approximately 0.6 second to detect ringing so a shorter ring burst is applied to CPE. The CPE answers the call by closing leads CT and CR through a resistive termination. This closure causes TR relay to operate causing line seizure, since PR relay was already operated by the ring detector. This causes the coupler to terminate the telephone

line and answer the incoming call. Two-way transmission is provided immediately on line seizure.

#### Disconnect Incoming Call

**4.05** The coupler will remain connected to the telephone line until it is caused to disconnect by the CPE removing the termination from leads

CT and CR. Relays TR and PR release disconnecting the coupler from the line.

#### LIST 15 TEST SET

**4.06** The List 15 test set (Fig. 6 and 8) used with the 1013A hand test set (or equivalent) and a connecting cable terminated in a plug for connection to the station coupler permits checkout of the coupler independent of the CPE.

**4.07** When detailed circuit description and operation information is required, refer to CD- and SD-69903-01.

#### 5. MAINTENANCE

**5.01** When trouble is reported verify that:

- Customer connector plug is secure in coupler.
- Power is supplied to station coupler with correct polarity.
- CO pair is good.

- Leads to CO line and telephone set are secure.
- Wiring options and coupler connections are correct. (Refer to Table A and Fig. 9.)

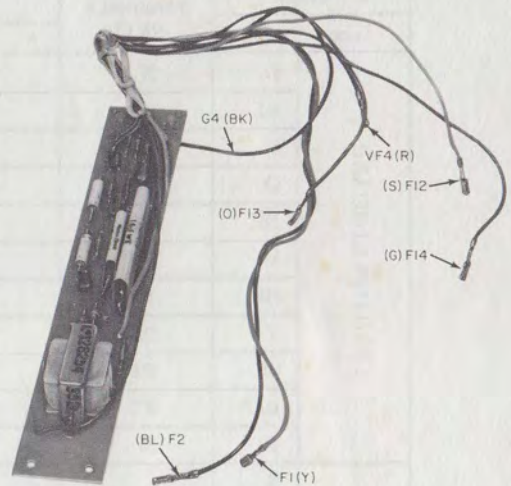

Fig. 5—KS-20721, List 14 Ring Supply

TABLE B  
WIRING OPTION FEATURES

OPTION	FEATURE
Q	Provides for direct control of line relay PR for dc pulse repeating without pulse correction.
Z	Connects transmission circuit to tip side of telephone line.
S	Provides talk battery to customer over transmission leads CT and CR.
P	Removes line seizure delay feature.
V	Adds List 11 circuit to provide dc pulse correction.
X	Adds List 14 circuit to provide 20-Hz ringing signal to customer over leads CR and RU1. (Does not provide bridged ringing.)



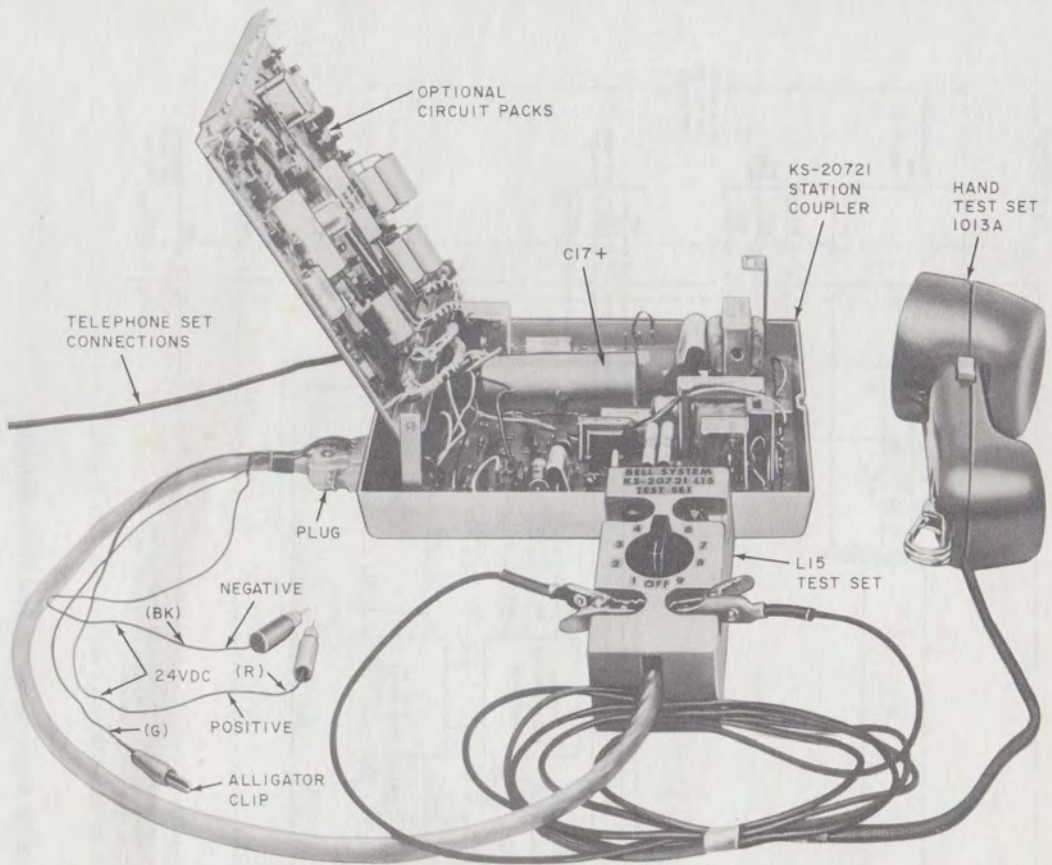

Fig. 6—KS-20721 Station Coupler with KS-20721, List 15 Test Set and 1013A Hand Test Set

**5.02** After performing steps in 5.01, if trouble still exists, perform the following test using the List 15 test set, or perform tests (place and receive calls) using the apparatus shown in Fig. 10).

**5.03 Apparatus Required:**

- List 15 test set
- 1013A (or equivalent) hand test set
- KS-6571 (or equivalent) battery (if coupler is powered by CPE).

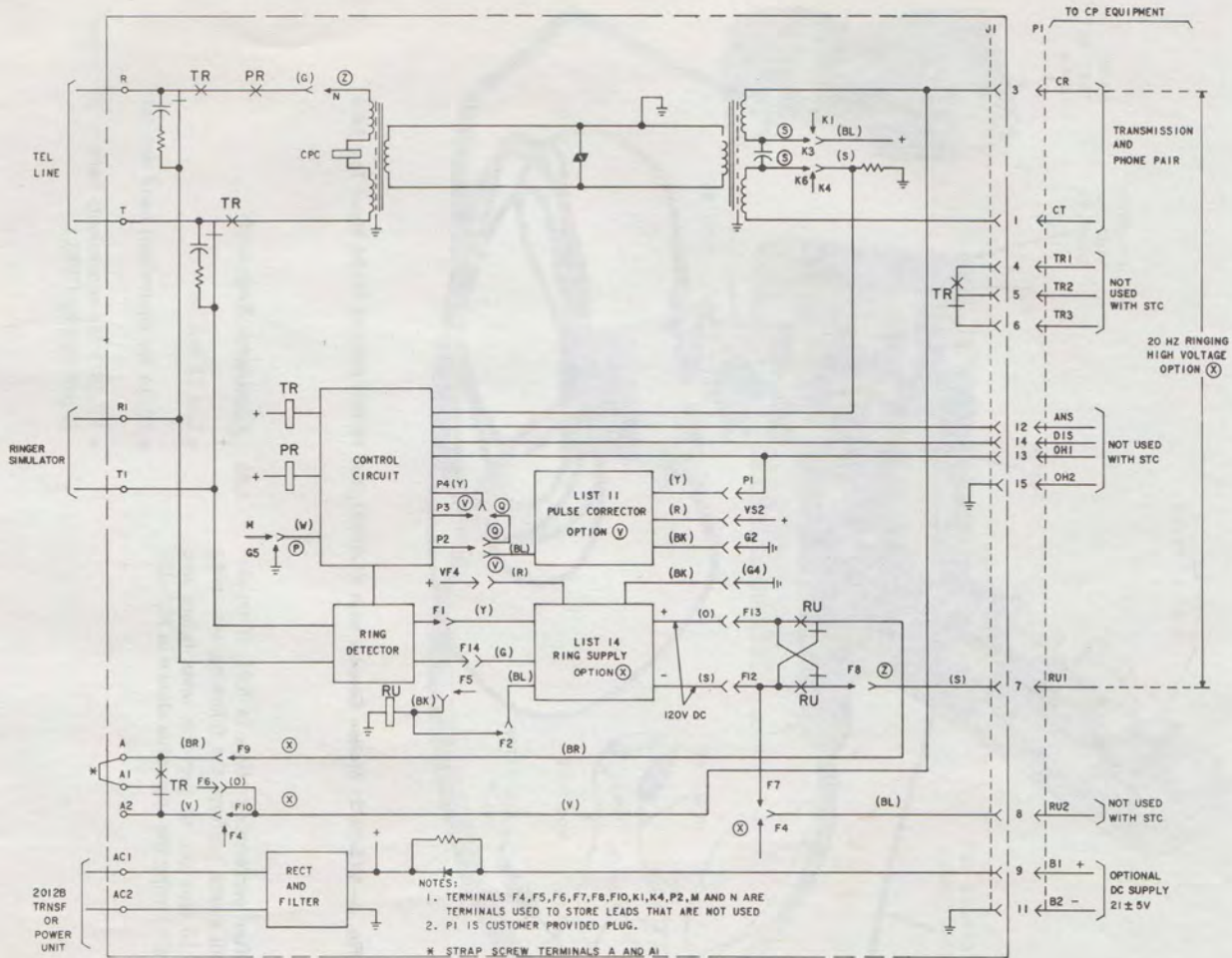

Fig. 7—KS-20721 Station Coupler Internal Wiring Options

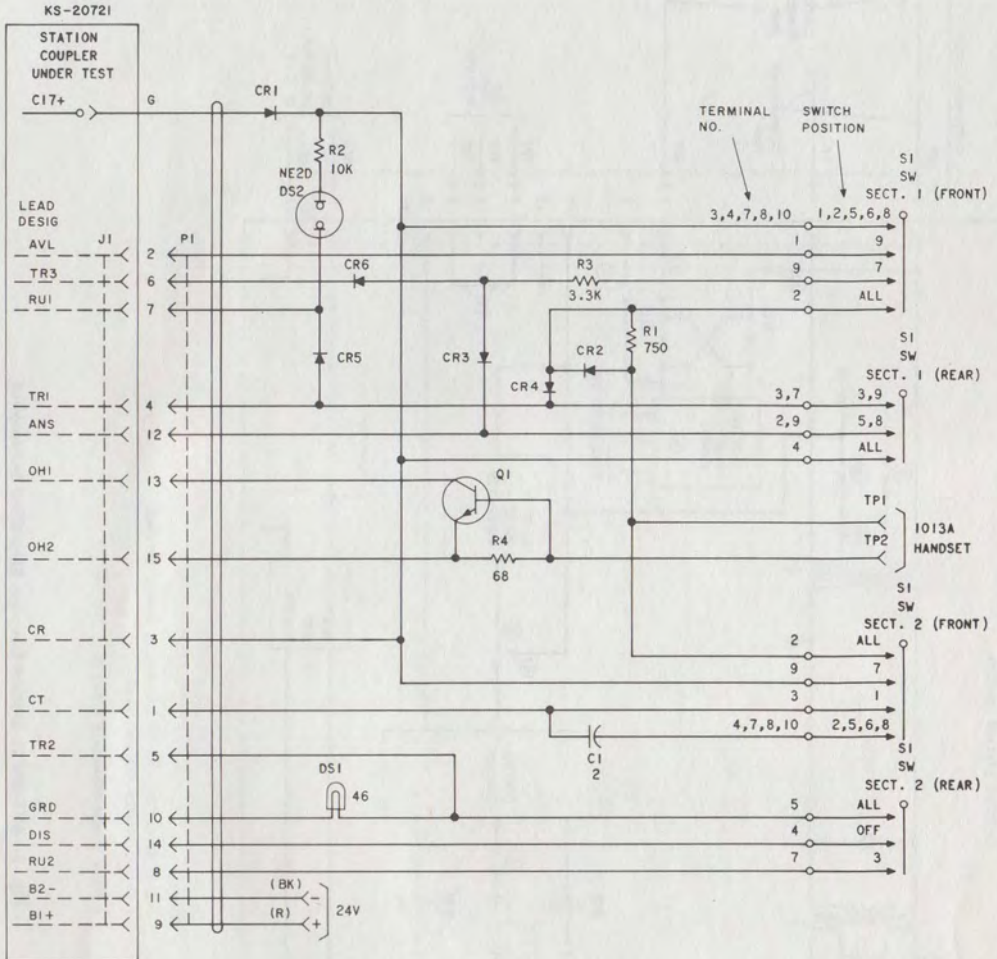
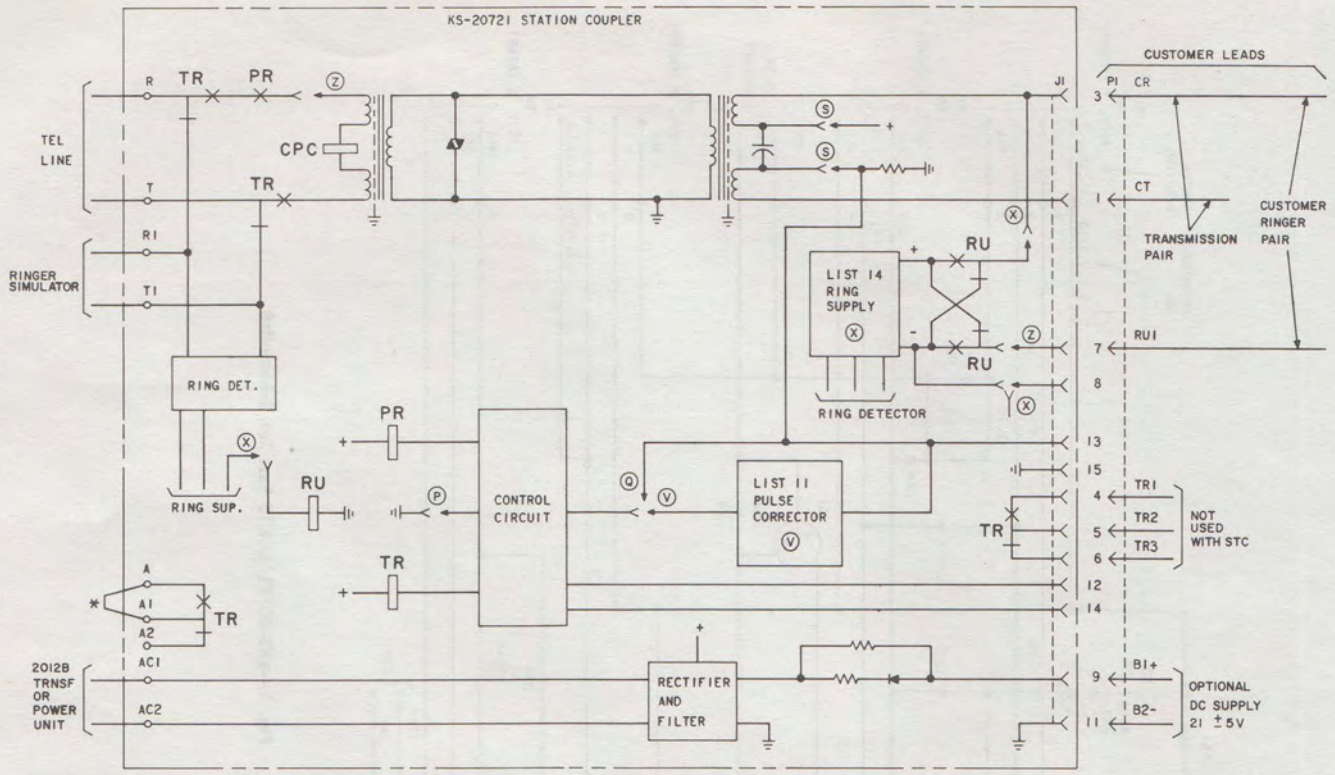

Fig. 8—KS-20721, List 15 Test Set, Schematic



NOTES:  
 1. CIRCLED LETTERS (Z), (X), ETC DENOTE WIRING OPTIONS.  
 2. PI IS CUSTOMER PROVIDED PLUG.  
 \* STRAP SCREW TERMINALS A AND AI.

Fig. 9—KS-20721 Station Coupler, Simplified Schematic

## 5.04 Preparation:



*Make all tests with CPE disconnected.*

STEP	ACTION	VERIFICATION
1	Rotate selector switch on List 15 test set to OFF.	
2	Remove cover of station coupler using KS-19192, List 1 tool or screwdriver.	
3	Connect a 1013A (or equivalent) hand test set to terminals provided on test set (Fig. 6).	
4a	If coupler is normally powered by CPE— Use a 24V (KS-6571 or equivalent) battery and connect the pin-tipped red lead from the test set to +24V and black lead to -24V.	
5	Connect test set plug to receptacle on station coupler. Do not connect alligator clip to C17.	White lamp extinguished. Red lamp extinguished.

## 5.05 Tests

STEP	ACTION	VERIFICATION
6	Operate switch on hand test set to MON. Rotate selector switch of test set to position 1.	White lamp lighted. Dial tone heard in hand test set receiver at <b>low</b> level.
7	Operate switch on hand test set to TALK. Rotate selector switch of test set to position 2.	White lamp remains lighted. Dial tone level increases. (Note presence of sidetone.)
8	Using the hand test set, dial the local test desk and request the testman to call back; proceed to next step immediately.	<b>Note:</b> If dial tone should time out before dialing, rotate selector switch back to OFF then proceed directly to position 2 for dialing.
9	Rotate selector switch of test set to position 4. Operate switch on hand test set to MON.	White lamp extinguished.
10	Testman returns call.	RU relay pulses and red lamp flashes (both elements) in unison with ring cycle.

STEP	ACTION	VERIFICATION
11	Rotate selector switch of test set to position 5 and operate switch on hand test set to TALK.	White lamp lighted. Red lamp stops flashing.
12	Request testman to release the line.	
13	Rotate selector switch of test set to OFF position.	White lamp extinguished.
14	Disconnect test set from station coupler and reconnect CPE.	



*An alternate method for testing the coupler may be used by placing a test call to check dialing, transmission and disconnect and receiving a test call to check ringing using the testing arrangement shown in Fig. 10. This test setup may be used when the List 15 test set is not available.*

- 5.06** If coupler does not meet the above tests, replace coupler and/or circuit packs.
- 5.07** If the tests are satisfactory, remove all test connections to restore circuit to normal and follow local reporting procedures for CP trouble.



*Do not attempt any test or repair to the CPE.*

- 5.08** When in the repairman's judgment the trouble is located in the CPE, the Repair Service Bureau should be notified so that proper Maintenance of Service Charge billing can be initiated as outlined in Section 660-101-312 entitled Maintenance of Service Charge on Services With Customer-Provided Equipment (CPE).

## 6. CONNECTIONS

- 6.01** Connections to the CPE are made through the 15-pin KS-19087, List 1 female connector on the coupler. The customer must furnish a suitable connecting cable equipped with a Cinch Manufacturing Co. or ITT-Cannon Electric No.

DA-19603-403 plug with a No. DA-51225-1 hood (or equivalent).

- 6.02** Provide the correct wiring options from Table A, connect the CO line and all associated Telephone Company-provided station sets to screw terminals T and R, and the 2012B power transformer (or 19-type power unit) leads to screw terminals AC1 and AC2. If an associated telephone set is not used (and no telephone set is on line), connect a ringer simulator (see 3.01) to terminals T1 and R1. Lightly tighten all unused terminal screws.

- 6.03** A 2012B transformer must not be used to supply more than one coupler. A suitable dc power supply (19-type or equivalent) may be used to supply multiple couplers (a maximum of ten couplers per 19-type power unit connected to the dc signal output). The dc power supply should be of the current limiting type, or it should be connected through a 20-ohm, 1-watt resistor to each coupler to provide current limiting. The power supply may be connected with either polarity to the AC1 and AC2 terminals. Do not ground either terminal of the power supply. Power supply current drain is 0.140 ampere maximum with all circuit packs in use. Initial surge current is 1 ampere and standby current is 0.012 ampere.

- 6.04** ⚡Line noise pickup, cross-talk, etc, may occur between units connected to a common power supply. When this occurs, it may be cleared by grounding the housing of each station coupler. The circuit board mounting screw below terminal A1 may be used for grounding the circuit.⚡

**6.05** When power is supplied by a 2012B transformer (or 19-type power unit), an optional current limited, positive dc voltage source is provided to the customer on lead B1 (ground return on lead B2) furnishing a charging current of 2.5 milliamperes which may be used to keep a CP rechargeable

battery (18V 150 to 500 ma) charged during normal operation to provide power when commercial power fails. If the customer furnishes power,  $21 \pm 5$  volts dc is connected to leads B1 and B2 through plug (P1).

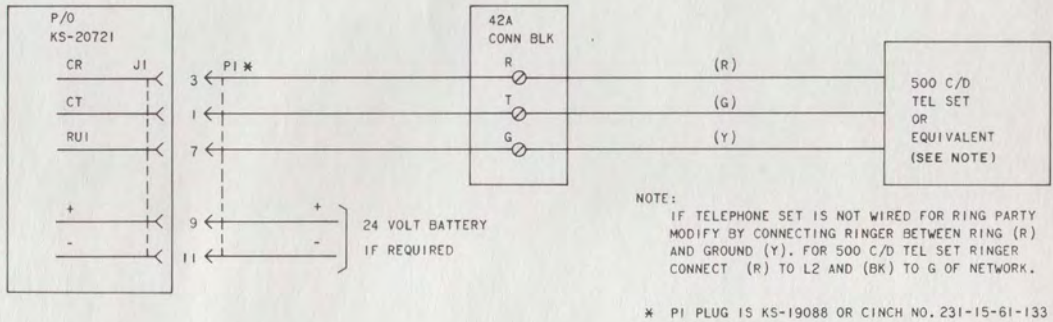

**Fig. 10—STC Test Circuit (Fabricate Locally)**