

COIN LEVEL DETECTOR

IDENTIFICATION, INSTALLATION, CONNECTIONS, OPERATION, AND MAINTENANCE

COIN TELEPHONE STATIONS

1. GENERAL

- 1.01 This section contains information on the coin level detector (CLD).
- 1.02 This section is reissued to:
- Revise Fig. 1
 - Revise paragraphs 3.04(10) and 3.05(8)
 - Add Note to Part 4
 - Add information on 1D- and 2D-type coin telephone sets.

2. IDENTIFICATION

- 2.01 The coin level detector is a device which provides a means for local or remote monitoring of the level of coins in the coin box of coin telephone sets.
- 2.02 The components necessary to incorporate the CLD are furnished as follows.
- (a) One D-180042 Kit of Parts (Fig. 1) is required to modify each telephone set housing. The kit consists of a terminal board assembly, contact spring assembly with hex nut and a lockwasher, an insulation strip, and a terminal board cover.
- (b) One D-180110 Kit of Parts (Fig. 2) is required to modify each coin box. The kit consists of a dual element sensor which clamps to the rear of the coin box.
- (c) A 1E coin receptacle cover (Fig. 3) is also required for each coin box. The 1E cover is similar to the 1D (MD) cover except it is equipped with a contact stud.



The 1E cover can be used with or without the CLD modification.

3. INSTALLATION

- 3.01 The following tools are necessary to perform the modification:
- 743A drilling template (Fig. 4)
 - 1/4-inch drill (Note)
 - Small C-clamp (2- to 3-inch)
 - Flat file.

Note: Telephone housings equipped with KS-19277 locks pose an interference problem with the 1/4-inch drill. The shank of the drill can be no greater than 0.175-inch diameter to permit drilling adjacent to the bolt fastener.

A. Modification of Coin Box

- 3.02 Replace the 1D coin box cover with the 1E cover (Fig. 5).
- 3.03 Clip the dual element sensor on the rear of the coin box (Fig. 5).

B. Modification of Coin Telephone Sets

- 3.04 Install D-180042 Kit of Parts in the 1A, 1C, or 1D coin telephone set as follows.

Note: Coin chute and coin chassis must be removed from 1A, 1C, or 1D coin telephone set. Refer to paragraph 3.05(1) for removal.⚡

NOTICE

Not for use or disclosure outside the
Bell System except under written agreement

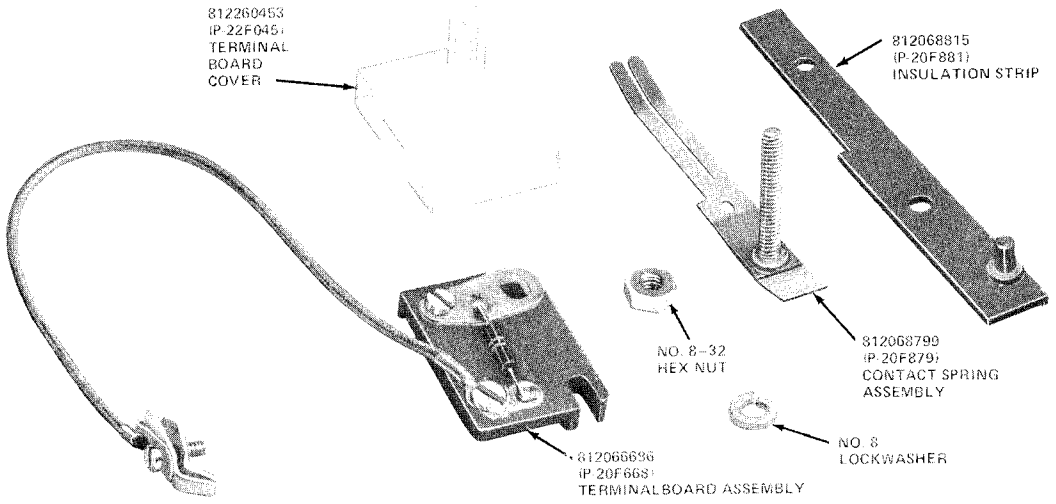

Fig. 1—D-180042 Kit of Parts

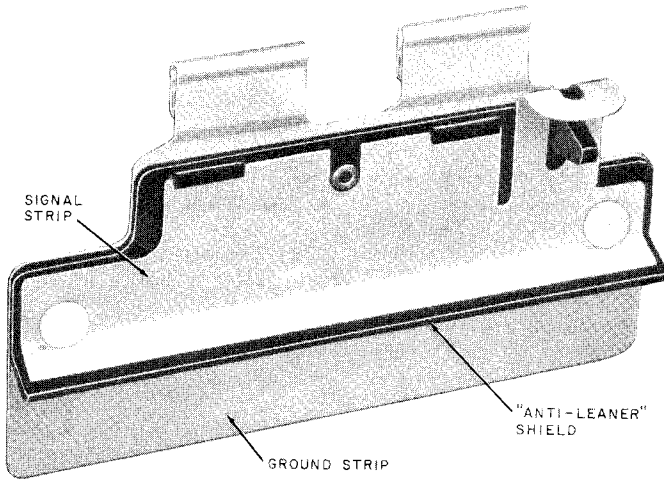

Fig. 2—D-180110 Kit of Parts

- (1) Remove the RH screw which secures the right front of the 1B rail to the lower housing.
- (2) Install the 743A template against the right side of the base as shown in Fig. 6 and secure it with the screw removed in (1).

Note: The positioning tab of the template must be inserted in the coin leveling hole.

- (3) Clamp the 1B rail to the housing during the drilling operation using the C-clamp described in paragraph 3.01.



Cover the coin relay, hopper, and return chute with a piece of plastic, cloth, or other suitable material to prevent metal drill shavings from falling into these mechanisms.

- (4) Using the 1/4-inch drill described in paragraph 3.01, drill the hole through the housing.
- (5) Remove the screw and drilling template.
- (6) Using the 1/4-inch drill, enlarge the hole where the screw was removed.
- (7) Using a suitable file, remove all burrs from the 1B rail.
- (8) Remove the C-clamp.
- (9) Remove all drill chips from the telephone set.
- (10) Position the insulation strip against the 1B rail with the boss on the strip in the 1/4-inch mounting screw hole (Fig. 7). Hold the contact springs in place with the stud extending through the hole drilled in the base, and fasten the terminal board in place on the housing base with the nut and lockwasher provided (Fig. 8).



◆ Tighten the 8-32 nut firmly (finger tight). Then using a suitable tool (wrench) tighten the nut an additional 90 degrees (quarter turn), NO MORE!

- (11) Reinstall coin chute and coin chassis [see paragraph 3.05(7)].

3.05 Install D-180042 Kit of Parts in 2A, 2C, or 2D coin telephone sets as follows.

- (1) Remove coin chute and coin chassis as follows.
 - (a) Disconnect P2 from J2 and remove coin chute.
 - (b) Disconnect (BK) and (Y) leads from coin relay and carefully pull leads through guide hole in hopper.
 - (c) Loosen chassis captive mounting screw.
 - (d) Pull chassis out at bottom, slide down, and remove.
- (2) Using the contact spring mounting hole as a guide (Fig. 9) drill through coin rail with 1/4-inch drill.
- (3) Remove the RH screw which secures the right front of the 1B rail to the housing assembly.



Cover the coin relay, hopper, and return chute with a piece of plastic, cloth, or other suitable material to prevent metal drill shavings from falling into these mechanisms.

- (4) Using the 1/4-inch drill, enlarge the hole where the screw was removed.
- (5) Using a suitable file, remove all burrs from the 1B rail.
- (6) Remove all drill chips from the telephone set.
- (7) Install coin chute and coin chassis as follows.
 - (a) Install coin chassis by reversing procedure in Step (1).
 - (b) Thread (BK) and (Y) leads of chassis through hole on coin hopper. Connect (BK) lead to terminal 3 and (Y) lead to terminal G of coin relay.
 - (c) Install coin chute and connect P2 to J2.

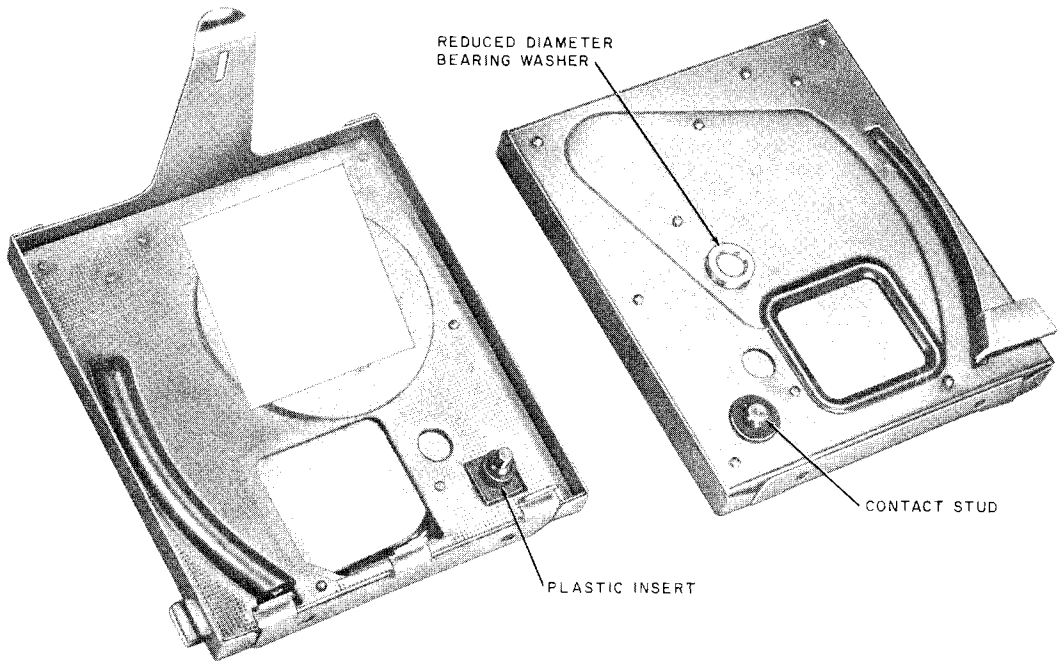

Fig. 3—1E Cover

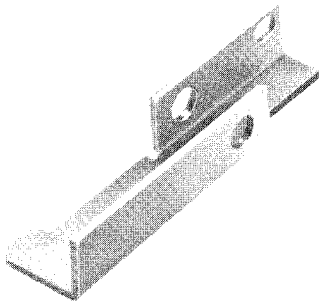

Fig. 4—743A Drilling Template

(8) Position the insulation strip against the 1B rail with the boss on the strip in the 1/4-inch mounting screw hole (Fig. 7). Hold the contact springs in place with the stud extending through

the hole drilled in the base, and fasten the terminal board in place on the housing base with the nut and blockwasher provided (Fig. 8).

C. Replacing Coin Box

3.06 Replace existing coin box with a modified coin box (Fig. 5).

4. CONNECTIONS

A. Remote Monitoring (Central Office Line Insulation Test)

Note: Remote monitoring will not work in dial-tone-first mode.

4.01 Remove coin relay cover.

4.02 The lead provided with the D-180042 Kit of Parts is equipped with a screw clamp to facilitate fastening to the ground tab on the coin

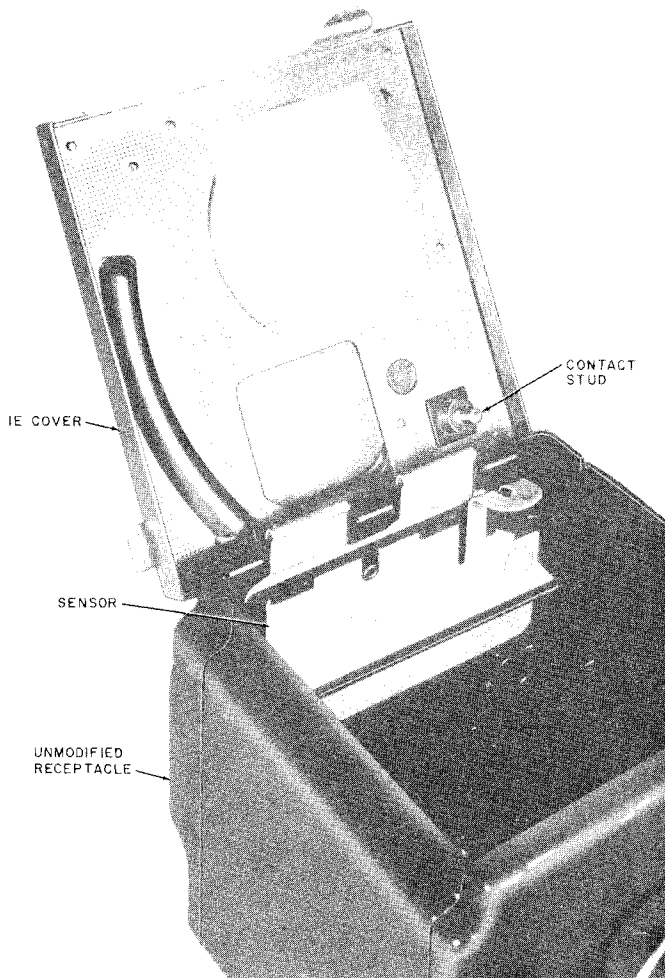

Fig. 5—Modified Coin Box

relay (Fig. 8). Care must be taken not to alter the adjustment of the coin relay by bending the spring member. Connect the spade tip of the lead to the front terminal on the terminal board.

B. Local Monitoring

4.03 Connect a lead from the rear terminal of the terminal board to the indicating device

through existing cable entries in the rear of the telephone housing.

4.04 Refer to Fig. 10 for connection diagram.

4.05 Install coin relay cover and terminal board cover (Fig. 11).

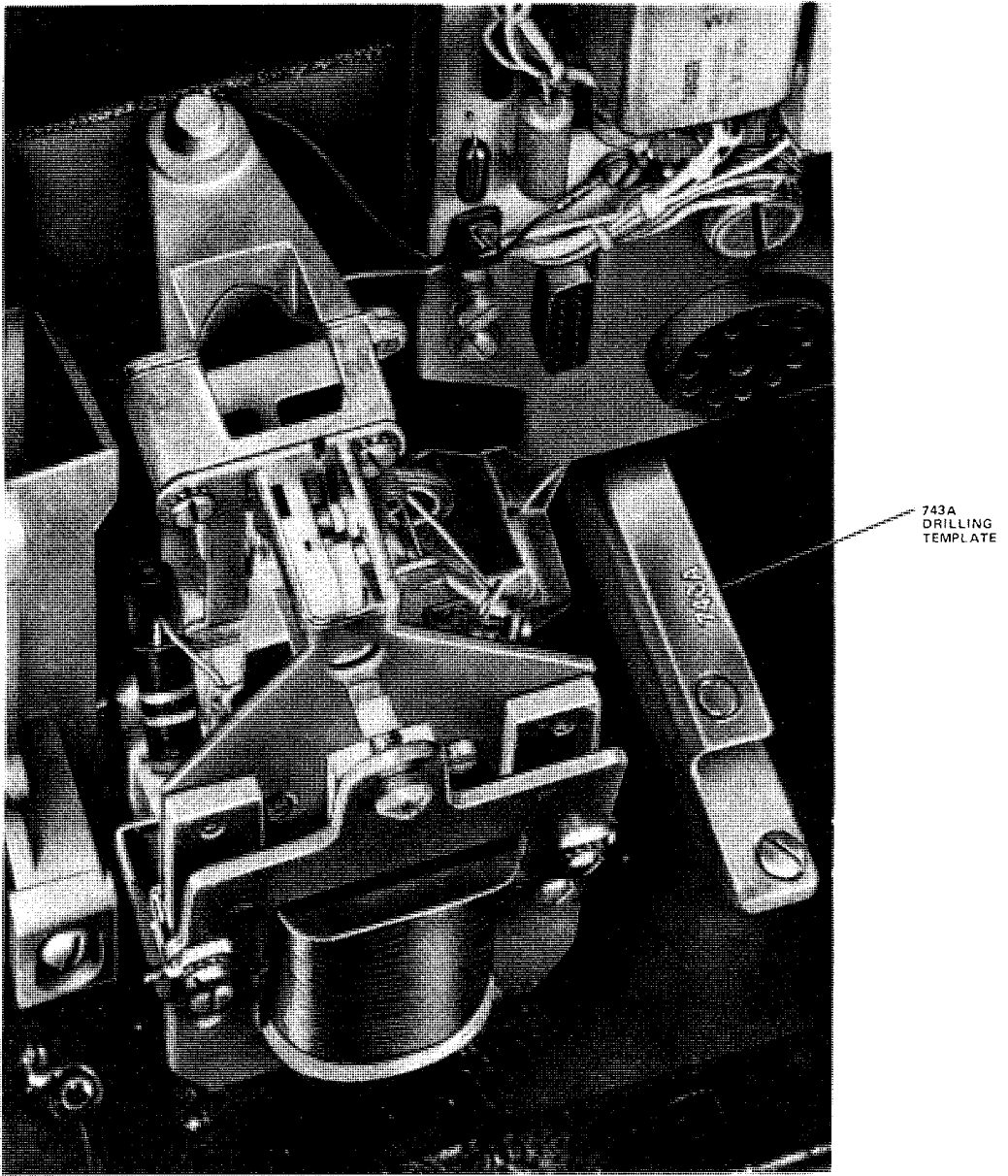

Fig. 6—Installation of Drilling Template

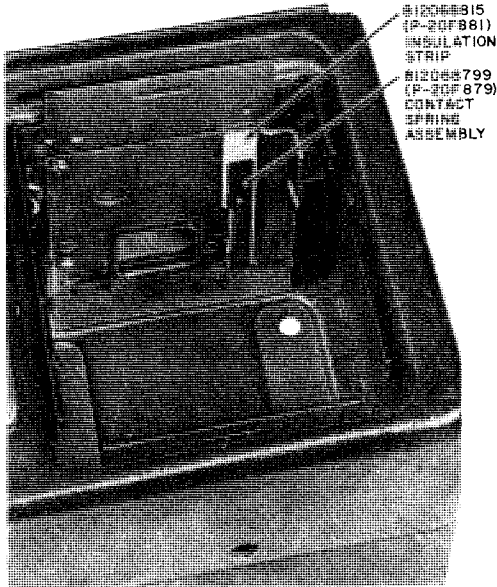

Fig. 7—Installation of Insulation Strip and Contact Spring Assembly

5. OPERATION

5.01 The dual element sensor is constructed of an insulated mounting plate with two conducting surfaces. One surface is grounded through the coin receptacle cover by spring clip contacts. The other conducting surface presses

against the insulated stud on the cover and carries a coin level signal through the spring contacts (mounted on the receptacle rail) to the terminal board on the base of the set housing.

5.02 Coins accumulating in the cash box will complete a circuit between the conducting surfaces of the sensor. A ledge between the conducting surfaces protrudes into the coin box and prevents coins from leaning against the sensor and prematurely indicating the coin level accumulation. The sensor is designed and physically mounted to provide an indication to local or remote monitors when the coin level reaches approximately 70 percent of the coin box capacity.

5.03 For local monitoring, a locally supplied lead is connected to the terminal board to complete the circuit to a visual indicator. Alternately, a supplied lead and clamp assembly complete the circuit, through a 51K resistor to the coin relay, to permit central office monitoring of the coin level circuit with line insulation test equipment. To prevent degradation of service, the 51K resistor is shorted by the hopper trigger contacts when the telephone is in use.

6. MAINTENANCE

6.01 Inspect for dirty spring contacts and positive ground contact between the sensor and the coin box cover. The insulated stud on the cover should be free of dirt and make a wiping contact with the upper plate of the sensor in the coin box. The top of the stud should make a wiping contact with the spring contact on the 1B rail when the coin box is installed in the vault.

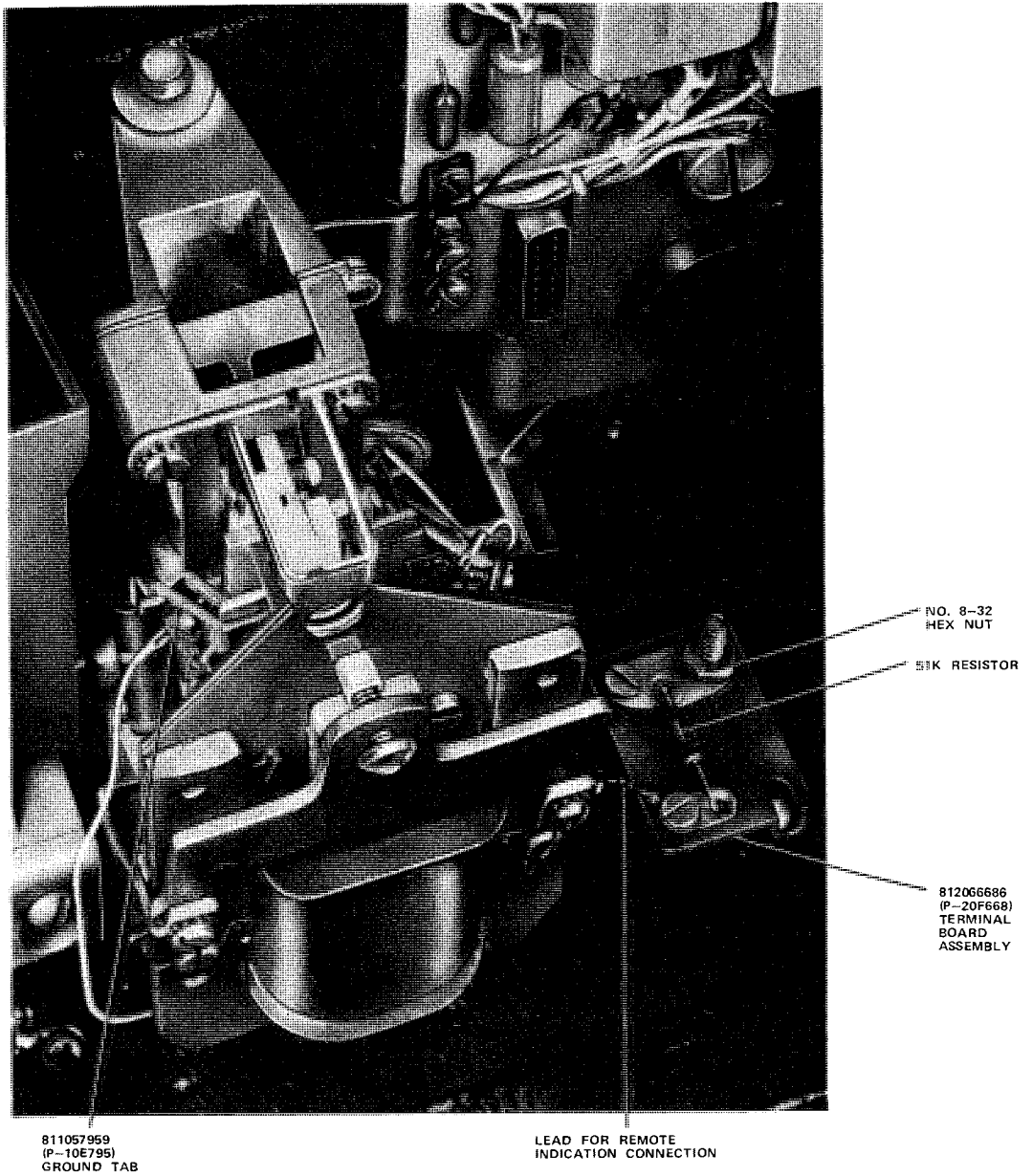

Fig. 8—Installation of Terminal Board Assembly

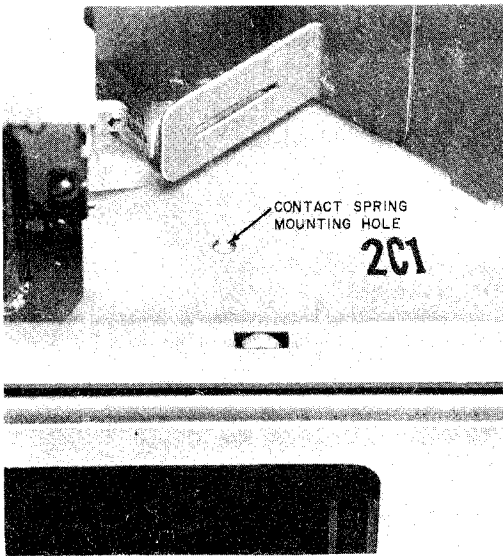

Fig. 9—Location of Contact Spring Mounting Hole in 2A, 2C, or 2D Telephone Sets

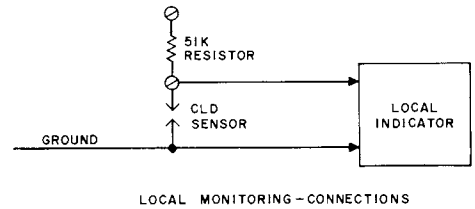
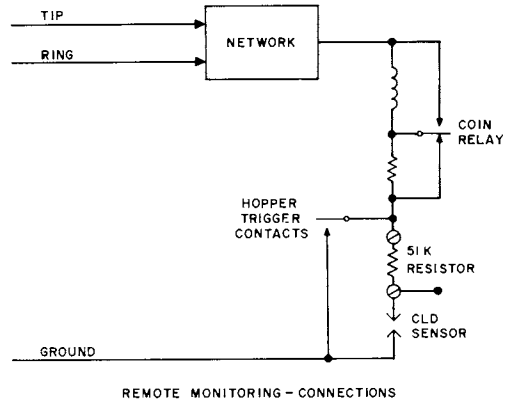

Fig. 10—Coin Level Detector—Connections

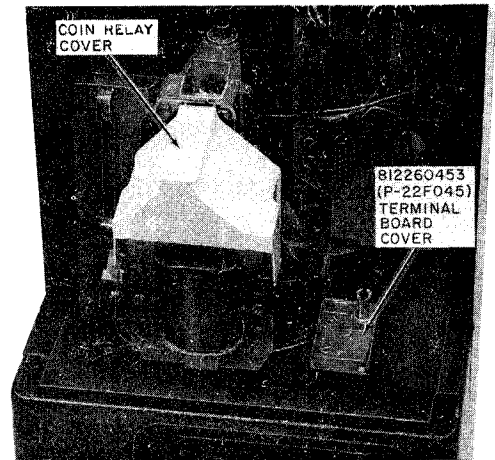

Fig. 11—Installation of Coin Relay Cover and Terminal Board Cover