

4A COMMUNICATION SYSTEM

COM KEY* 416

CONTENTS	PAGE
1. GENERAL	1
2. IDENTIFICATION	2
BASIC FEATURES	2
OPTIONAL FEATURES	2
TELEPHONE SETS	3
ORDERING GUIDE	4
3. INSTALLATION	8
PLANNING	8
INSTALLING	9
OPTIONS	10
4. CONNECTIONS	24
5. METHOD OF OPERATION	24
6. MAINTENANCE	27

1. GENERAL

1.01 This section provides identification, installation, connection, and maintenance information for the 4A Communication System (COM KEY 416).

1.02 This section is reissued to add five system adjuncts:

- 24A Apparatus Unit
- 25A Apparatus Unit
- 26A Apparatus Unit

*Trademark

• 27A Apparatus Unit

• 109A Loudspeaker

1.03 The system provides basic line services such as pickup, hold and illumination, one or two intercom paths, tone and voice signaling, multiline conferencing, built-in loudspeaker service, flexible tone ringing, automatic button restoration (ABR), outgoing service during power failure, privacy release, and recall (operator flash when used behind a PBX). Available optional features are privacy, music-on-hold (utilizing customer-provided music source), external ringing, power failure ringers, supplementary alerting device access, preset multiple signaling, customer-owned paging access wall loudspeakers, station restriction and TOUCH-TONE® dialing. TOUCH-TONE and rotary sets may be intermixed in the same system without additional equipment.

Note: Speakerphone capability is not provided.

1.04 The 4A System has a maximum capacity of 4 CO/PBX lines and 16 stations. Two basic types of telephone sets, called primary and satellite, are employed. Each primary station contains the logic circuitry, power supply and clock circuitry for two CO/PBX lines and one intercom path. For small systems, one primary set may be used to provide two CO/PBX lines, one intercom path, and up to seven satellite stations. The addition of the second primary station simply doubles the system capacity. Satellite station sets provide the same service as primary station sets except they do not contain any control circuits.

1.05 Every station can be programmed to ring on any combination of CO/PBX lines. All stations have access to all lines in the system; therefore, an attendant may or may not be used.

1.06 The system components are protected by a self-resetting thermal cut-off in the power

NOTICE

Not for use or disclosure outside the
Bell System except under written agreement

supply of the primary stations, making separate fusing unnecessary.

2. IDENTIFICATION

2.01 The 4A System provides up to 4 CO/PBX lines, up to 16 stations and 2 intercom paths. A brief description of system features is listed.

BASIC FEATURES

- (a) **Pickup, Hold, and Illumination**—Standard key system pickup, hold and line status lamp rates, including wink hold.
- (b) **2-Path Intercom**—Each intercom path is associated with a separate button and lamp on each telephone set.
- (c) **Multiline Conferencing**—Two or more CO/PBX lines may be conferenced by *simultaneously* depressing the line buttons of the lines to be conferenced.

Note: Intercom and CO/PBX lines cannot be conferenced together.

- (d) **Tone and Voice Signaling**—CO/PBX line alerting signal is by tone source rather than conventional ringer. By lifting the handset, selecting an idle intercom path, and depressing a DSS button, the calling station may voice-signal the called party. Multiple stations may be signaled by depressing more than one DSS button at a time.
- (e) **DSS Volume Control**—Allows called party to adjust volume of voice signaling on DSS call.
- (f) **Built-in Loudspeaker Service**—By depressing the button designated SPKR, the telephone set user can bridge the speaker in his set onto the receiver of his handset. This enables others in the room to hear both sides of a conversation. If so desired, this feature may be disabled by the installer.
- (g) **Automatic Button Restoration**—ABR returns depressed line or intercom buttons to the unoperated position when the handset is replaced on the set.

(h) **RECALL**—Used to drop a line in order to receive a second dial tone without going back on-hook. When the telephone set is used behind a PBX, a momentary depression of the RECALL button will signal the attendant (similar to switchhook flash function).

(i) **CO/PBX Ringing**—Each station can be arranged to ring on all lines, any combination of lines, or not at all. Ringing is programmed at each station set and is customer accessible.

(j) **Wall Mounting**—Provides necessary hardware (D-180658 kit of parts) to wall-mount a satellite set.

Note: Primary sets cannot be wall-mounted.

(k) **Privacy Release**—Privacy release allows a station to permit privacy-equipped stations that have been locked out of call to bridge into the conversation. All 4A System telephone sets are factory-wired with privacy release.

OPTIONAL FEATURES



The following features should be implemented only when specifically covered in the service order.

(l) **Privacy**—Privacy prevents a station from bridging into a CO/PBX call in progress.

Note: Intercom lines have no privacy.

(m) **Music-on-Hold**—Provides music from customer-provided music source to calls placed on hold.

(n) **External Ringing**—External ringing may be provided by connecting an external ringer across the CO/PBX tip and ring leads at the primary station.

(o) **Station Restriction**—Provides for outgoing call restriction by changing dial connections in telephone set.

(p) **TOUCH-TONE Set**—Provides TOUCH-TONE dialing. Rotary and TOUCH-TONE dial sets may be intermixed in the system without additional equipment.

- (q) **Power Failure Ringer (24A Apparatus Unit)**—Provides two C4A ringers and associated circuitry to connect the ringers to the telephone lines in event ac power to the 4A Communication System is disrupted. One apparatus unit is required for each primary set in the system to be provided with power failure ringing.
- (r) **Supplementary Alerting Device Interface (25A Apparatus Unit)**—Provides circuitry to accept an input from one designated direct station selection (DSS) button and/or any combination of four common audible leads to provide an output capable of driving a dc relay for ringing bells, gongs, horns, etc.
- (s) **Preset Multiple Voice Signaling (26A Apparatus Unit)**—Provides preset multiple voice signaling which permits the customer to activate a combination of DSS addresses by depressing one designated DSS button. This feature is used for group signaling, all-page, emergency, etc.
- (t) **Paging Access (27A Apparatus Unit)**—The 27A is an interface adjunct which provides the electrical interface between the 4A Communication System and a customer-provided paging system. The circuit provides for a single DSS input, a music input from a 33A voice coupler, and a drive circuit for an external relay which, when required by the customer paging system, will provide a contact closure when paging occurs.
- (u) **109A Loudspeaker Set**—The 109A loudspeaker set includes speaker, amplifier, and two volume controls in a wood housing designed for wall mounting. The 109A is intended for indoor use only and is not intended for use in high noise level environments. The two customer accessible volume controls are for background music and paging volume.♦

TELEPHONE SETS

- 2.02** The 4A System uses telephone sets designed for this system (Fig. 1 and 2). They are not compatible with other systems.
- 2.03** Two types of telephone sets are used in the system. The satellite set contains speech circuitry, line pickup key, DSS key, and loudspeaker. The primary set is a slightly larger set which, in addition to the components of the satellite set,

contains the logic circuit to provide hold and lamp control for two CO/PBX lines and lamp control for one intercom line. Solid state lamps are associated with each line pickup button to indicate ringing, hold, active, or idle status by standard flashing rates, steady lamps, or no lamps. Intercom status is also indicated by an ON or OFF lamp.

2.04 Each telephone set contains a 664A (DSS) key, a speaker and volume control, and a 647M6 (10 button) key. The DSS field is interconnected with the intercom buttons. After selecting one of the idle intercom paths, the user must depress the desired DSS button which connects his handset transmitter to the speaker in the telephone set associated with that DSS button. The DSS button must be held depressed for the duration of the one-way voice transmission. Although the voice signaling path is unidirectional, the called station may establish a 2-way path by lifting his handset and depressing the intercom button on his set as instructed by the calling party. Calling party may then release DSS button. Multiple stations may be signaled by depressing more than one button at a time or the preset multiple voice signaling option may be used. The 664A key has a slide programming switch which connects that set speaker to the DSS number desired for that station. This key also has four vertical OFF-ON switches which control common audible ringing at the station. The loudspeaker located under the telephone set handset receives both the tone and voice signaling. Loudness is controlled by the volume control. Button assignments of the 647M6 key are: HOLD, four CO/PBX lines, two intercom paths, privacy-release (PRIV RLS), built-in loudspeaker service (SPKR), and RECALL. The SPKR button may be disabled by the installer if this feature is not desired by the customer.

2.05 The 4A System will interface with all PBXs except that it cannot provide for ground-start operation of CO trunks which bypass the PBX in the event of PBX power failure. In all other respects, the system performs on PBX lines in the same manner as on CO lines. For PBX use, the only restriction on the number of telephone sets is that each 25-pair connector cable system can serve a maximum of 2 primary stations and 14 satellite stations. Although 4A System telephone sets in each system have full capabilities, they can contact telephone sets in other systems only via PBX lines. To signal the PBX operator, the RECALL button should be used.



Fig. 1—2836AM-50 (Primary) Telephone Set

ORDERING GUIDE

- Set, Telephone (order as required):
 - 836AM-50 (rotary dial primary set)
 - 837AM-50 (rotary dial satellite set)
 - 2836AM-50 (TOUCH-TONE primary set)
 - 2837AM-50 (TOUCH-TONE satellite set)
- Note:** Sets are supplied in ivory-50 only and are shipped with a disposable faceplate. Desired faceplate must be ordered separately.
- Plate, Face, 836A—* (for 836AM or 837AM)
- Plate, Face, 2836A—* (for 2836AM or 2837AM)

*Add color suffix as follows:

- Avocado—100
- Teak—108
- Walnut—109
- Gold—111
- Orange—112
- Brown—113
- Red—114
- Blue—115
- Black—118



A. DESK CONFIGURATION



B. WALL CONFIGURATION

Fig. 2—837AM-50 (Satellite) Telephone Set

- Kit of Parts, D-180658 (one required for each 837- or 2837-type set to be wall-mounted)
- Block, Connecting, 91A (order one for each primary station).

Order the following, as required, depending on the job requirements. Refer to Fig. 3 and 4 for typical wiring arrangements.

- Adapter, Bridging, KS-19252 (order by list number as required) (Fig. 3)
- Cable, Connector, B25A (specify desired length) (Fig. 3)
- Block, Connecting, 66E3-25 (Fig. 3)
- Block, Connecting, 66B4-25 (Fig. 4)
- Cable, Connector, A25B (specify desired length) (Fig. 4)
- Backboard, 184B1 (Fig. 4).

Optional Apparatus (Order as Required)

- Coupler, Voice, 33A (one required when music-on-hold or background music is provided)
- Kit of Parts, D-180605 (one required for each primary station to be equipped for music-on-hold)
- Kit of Parts, D-180604 (privacy circuit, one required for each station to be locked out)
- Unit, Apparatus, 24A (one required for each primary set to be equipped for power failure ringing)
- Unit, Apparatus, 25A (one required for each KS relay used to operate auxiliary signals)
- Unit, Apparatus, 26A (one per each DSS zone designated to access any combination of the other DSS zones in the system)
- Unit, Apparatus, 27A (one per customer-provided paging system)
- Set, Loudspeaker, 109A
- Block, Connecting, 91A (one required for each 109A loudspeaker in system)
- Relay Set, KS-16626, L12 (if required)♦

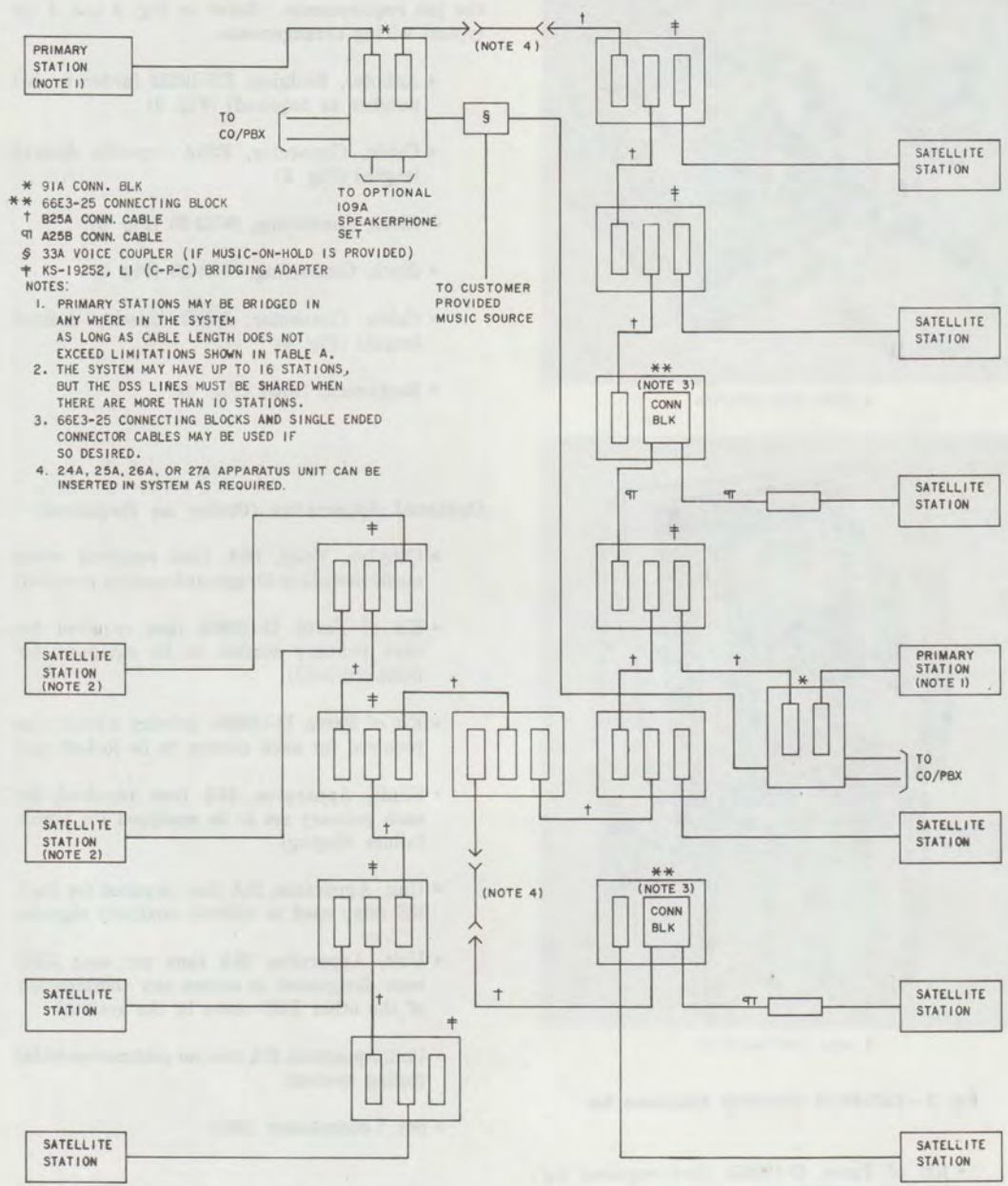
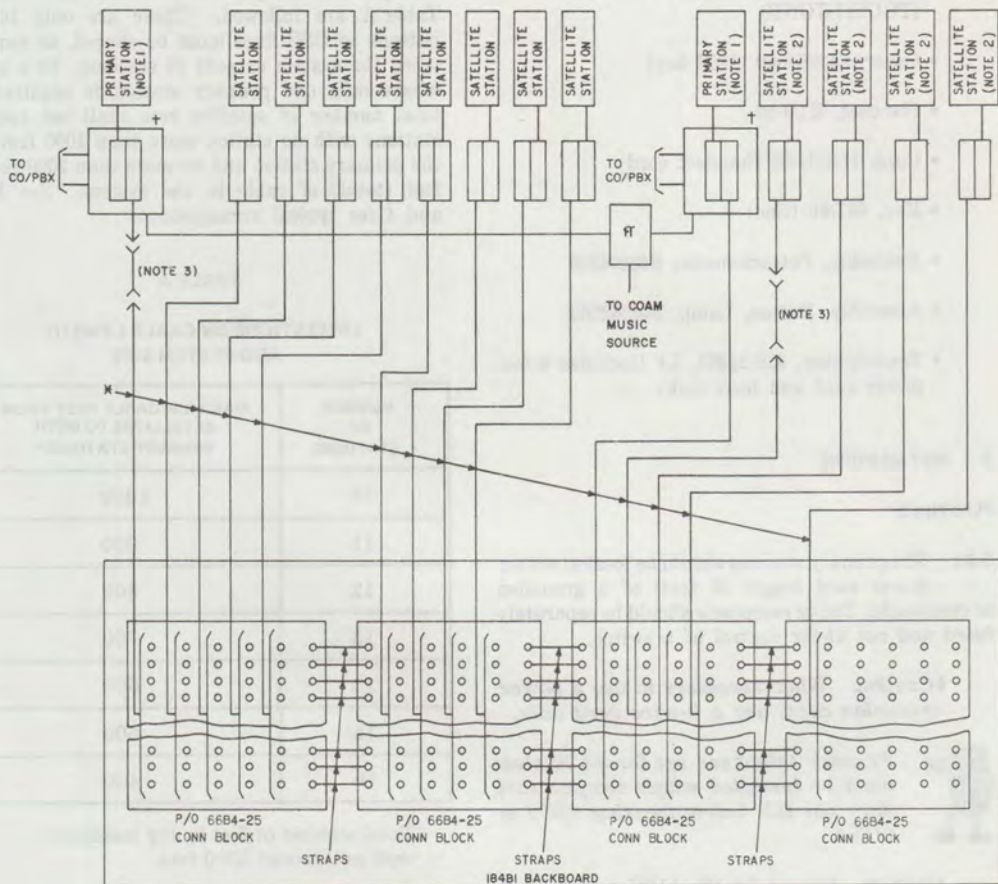

Fig. 3—Typical Installation, Using Bridging Adapters and Connecting Blocks



NOTES:

1. CONTROL STATIONS MAY BE BRIDGED IN ANYWHERE IN THE SYSTEM AS LONG AS CABLE LENGTH DOES NOT EXCEED LIMITATIONS SHOWN IN TABLE A.
2. THE SYSTEM MAY HAVE UP TO 16 STATIONS HOWEVER, DSS LINES MUST BE SHARED WHEN THERE ARE MORE THAN 10 STATIONS.
3. INSERT 24A, 25A, 26A, OR 27A APPARATUS UNIT IN SYSTEM AS REQUIRED.

* A25B CONN. CABLES (SINGLE-ENDED)

+ 91A CONNECTING BLOCK

3A 33A VOICE COUPLER (IF MUSIC ON HOLD IS PROVIDED)

Fig. 4—Typical Installation Using Home Run Method

Replaceable Components

- Dial, 8DT-119 (rotary) or 35AH3D (TOUCH-TONE)
- Cover, 840994560 (DSS key)
- Handset, K1B-50
- Cord, H4DU-50 (handset cord)
- Key, 647M6 (line)
- Assembly, Potentiometer, 840694350
- Assembly, Button, Lamp, 840362263
- Transformer, KS-21361, L1 (includes 6-foot power cord and heat sink)

3. INSTALLATION**PLANNING**

3.01 The primary stations should be located within power cord length (6 feet) of a grounded ac receptacle. The ac receptacle should be separately fused and not under control of a switch.

⚠**Caution:** When necessary to use a power extension cord, use a 3-wire cord only.



Primary telephone set for 4A System must be installed where temperature does not fall below freezing (32°F or 0°C).

Caution: Except for the 110V power cord, no connection shall be made between any point in this system and building ground.

3.02 Normally, a 4A System installation will consist of up to 10 stations with a maximum of 16 stations if DSS codes are shared (primary stations included). The following cable restrictions apply to any installation:

- There should be no more than 1000 running feet of cable between any satellite station and both primary stations.
- No more than 2000 running feet (total) of cable should be used in any installation.

The 4A System can be expanded to a maximum of 16 stations (including primary stations and 109A loudspeaker sets) provided the cable restrictions in Table A are followed. There are only 10 DSS buttons so DSS lines must be shared, as required, when the system exceeds 10 stations. In a system where only one primary station is required, the total number of satellite sets shall not exceed 7 stations with no station more than 1000 feet from the primary station and no more than 2000 running feet (total) of cable in the system. See Fig. 3 and 4 for typical arrangements.

TABLE A

LIMITATIONS ON CABLE LENGTH AND SYSTEM SIZE

NUMBER OF STATIONS	MAXIMUM CABLE FEET FROM SATELLITES TO BOTH PRIMARY STATIONS*
10	1000
11	900
12	800
13	700
14	600
15	500
16	400

*Total number of feet in any installation shall not exceed 2000 feet.

3.03 Select appropriate apparatus according to job requirements (see ORDERING GUIDE).

3.04 ⚠The apparatus units are to be mounted at a location where convenient access to the cabling system is provided.

3.05 The following precautions are to be considered as to location of installation:

- (a) The 24A apparatus unit is to be located near any telephone set where this feature is required.



The 24A apparatus unit must be mounted on a vertical surface, so the mercury relay (Fig. 15) on the printed wiring board is in a vertical position as indicated on the relay cover.

- (b) The 26A apparatus unit is to be installed in indoor location (above 32°F).
- (c) The 27A apparatus unit is to be installed in indoor location (above 32°F) and mounted so the customer has access to screw terminals A1 and A2.
- (d) The 109A loudspeaker is designed for indoor locations (above 32°F). Speakers reach a depth of 30 feet. If a room is over 30 feet wide, facing speakers should be used (Fig. 24).

Note: Care shall be taken in location of speaker(s) (Fig. 24) to avoid feedback when paging from nearby stations. Spacing of up to 30 feet may be required between the speaker(s) and station sets.♦

INSTALLING

3.06 Install 91A connecting blocks and KS-19252 bridging adapters, or 66E3-25 connecting blocks, at desired locations using shortest length of connector cables. Also install wall brackets from D-180658 kit of parts where wall sets are to be installed. Use proper mounting hardware depending on wall surface.

3.07 Use care when unpacking telephone sets to avoid damage. Install sets in desired locations.

3.08 Primary sets are factory-wired so that the CO/PBX lines appear on lines 1 and 2 and the intercom on IC1. If the system uses two primary sets, one must be modified to move the line appearances to 3 and 4 and IC2 as follows:

- (1) Unplug 110V power cord from power receptacle if connected. Remove the power transformer assembly by pulling out on the bottom of the heat sink. If desired, a screwdriver may be used to carefully pry the transformer loose (Fig. 5). **Do not pull on transformer cord.**
- (2) Remove line assignment connector (Fig. 6) by pulling straight up until connector clears



Fig. 5—Removing Transformer

pins on circuit board. **Take care not to bend pins on circuit board.**

- (3) Rotate connector 180 degrees so that side labeled lines 3 and 4 can be seen.
- (4) Reinsert connector so that outside row of holes (toward rear of set) mate with pins on board.
- (5) Replace transformer and heat sink assembly.
- (6) Plug in power cord.

3.09 The DSS programming switch and common audible switches (Fig. 7) must be set as required at each station as follows:

- (1) Raise cover either by pressing on the extreme left end to tilt the cover or pry up the right end of the cover using a fingernail.
- (2) Determine the DSS code for that station and slide the program switch to that number. For example, Fig. 7 shows the station designated as DSS code 7.



More than one station set may be programmed for the same DSS code. Also, a set may be programmed so that it does not have a DSS code by moving the switch to the OFF (extreme left) position. When positioning the program switch, take care to correctly position the switch in a detent.

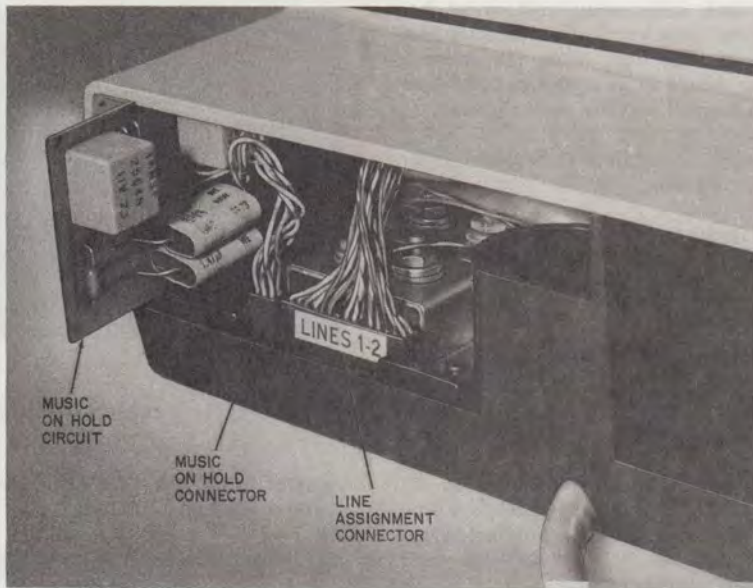

Fig. 6—Line Assignment Connector and Music-on-Hold Board

- (3) Select CO/PBX lines to ring at the stations by positioning the common audible switches to the ON position.
 - (4) Close switch cover.
- 3.10** Modify 837- or 2837-type telephone sets that are to be wall-mounted as follows:
- (1) Loosen four screws and remove the lower housing.
 - (2) Remove screw holding mounting cord attachment bracket at rear of set.
 - (3) Refasten bracket using screw in the position shown in Fig. 8.
 - (4) Rotate the lower housing 180 degrees from the desk model position and fasten housing to base.
 - (5) If plastic designation card cover has been installed, remove cover using a KS-16750 releaser, then remove screw from recess and discard screw.
 - (6) Install plastic handset hook (Fig. 9) from the D-180658 kit of parts using longer screw also furnished with kit.
 - (7) ♦Replace plastic designation card cover.♦
- 3.11** The telephone set can be mounted with the mounting cord either run vertically down the wall or through a customer-provided opening in the wall. The set is mounted on the wall bracket supplied with the kit of parts by positioning the set, so that the four tabs on the bracket engage the openings in the lower housing, and sliding the set downward until the snap-lock engages. Check to make sure that all tabs are engaged and the set locked on the bracket. To remove the set, press the tab on the wall bracket, which extends below the set, toward the wall while pushing the set upward.
- OPTIONS**
- 3.12 External Ringer**—Connect leads from E1C ringer to screw terminals on 91A connecting block associated with primary telephone sets as shown in Table B. If an external ringer is desired

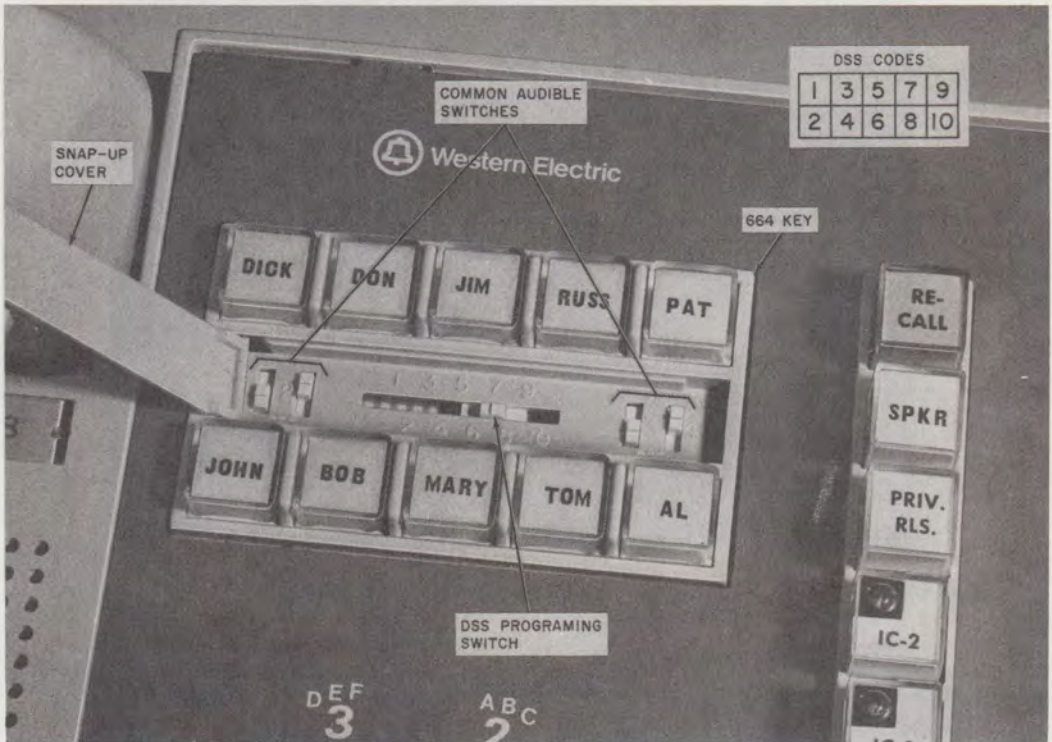

Fig. 7—DSS Key

at a satellite station, install the ringer at that location using D inside wire to connect it to the proper R () and T () terminals of the primary set 91A connecting block. **Do not attempt to wire ringer to any other pair in the system. Do not connect more than three EIC ringers to any CO/PBX line.**

3.13 Dial Restriction—Restrict stations as follows:

- (1) Remove faceplate by inserting a KS-16750 tool in the notch near the center of the faceplate and raising upward to bow faceplate (Fig. 10).
- (2) Loosen two captive screws holding DSS key and move key to side.

(3) On a TOUCH-TONE set, move the O-BK lead from terminal 36 to 31; on rotary sets, move the BL-R lead from terminal 28 to 39.

(4) Replace DSS key.

(5) Install faceplate by inserting in slots at bottom of set and bowing it until it will slide in slots at top of set (Fig. 11).

3.14 Music-On-Hold—This option requires the installation of a D-180605 kit of parts at each primary telephone set and one 33A voice coupler per system.

(a) Install kit of parts in the primary set(s) as follows:

- (1) Remove transformer as covered in 3.08 (1).

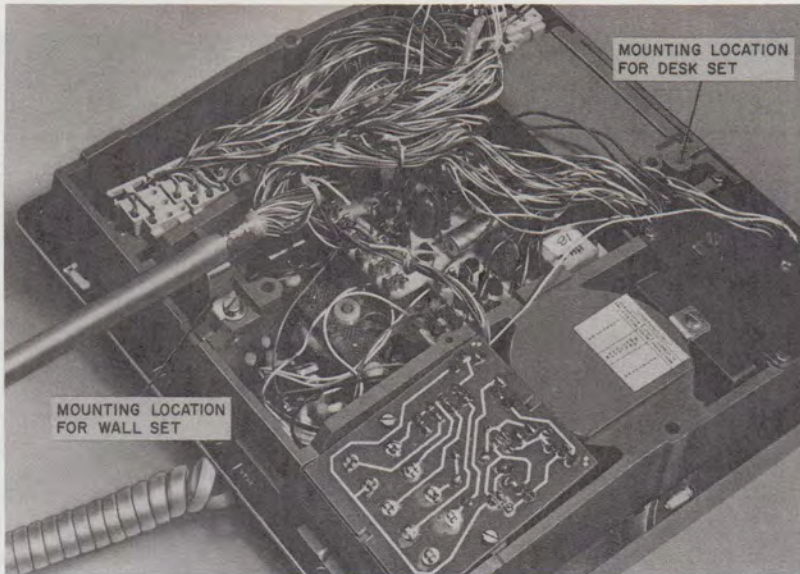

Fig. 8—Set Modification For Wall Mounting

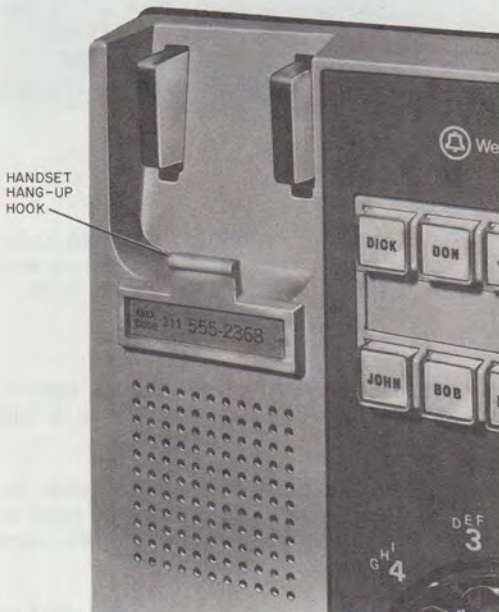

Fig. 9—Handset Hook Attachment For Wall Set

(2) Insert music-on-hold circuit board vertically in slots provided in upper and lower housings (Fig. 6).

(3) Plug in connector from circuit board to the pins provided as shown in Fig. 6. The connector may be plugged in either way.

(4) Replace transformer and heat sink assembly.

(5) Plug in power cord.

(b) Install the 33A voice coupler as follows:

(1) Remove cover from coupler.

(2) Mount coupler at location which permits customer to make connections and also allows connection to system.

Caution: Ensure that 35P fuses are installed with the spring at the bottom (Fig. 12) and set the volume control at approximately mid-range.

(3) Connect primary station(s) to the voice coupler per Table C.

TABLE B
EXTERNAL RINGER CONNECTIONS

RINGER ON CO/PBX LINE	PRIMARY STATION	CONNECT LEADS	
		FROM 91A CONN. BLOCK	TO E1C RINGER TERM.
1	1	R1	5
		T1	6
2		R2	5
		T2	6
3	2	R1	5
		T1	6
4		R2	5
		T2	6

Note: Use inside wire to make connections.

- (4) Replace cover.
- (5) Have customer connect his music source as shown in Table C.



The customer-provided music source must be capable of providing one watt of undistorted RMS power into an 8-ohm load. In addition, the output of the music source must be ac coupled. Do not connect a source that has a dc voltage on the output.

- (c) Adjust volume level for music-on-hold as follows:
 - Place a call to a station in the system.
 - Answer call and place it on hold.
 - Have customer adjust his music source for a comfortable listening level at the held station.

Note: The 33A voice coupler will accept input from any customer-provided apparatus that does not blow a fuse in the voice coupler.

A copy of the technical reference covering the 33A voice coupler can be obtained by contacting the Telephone Company Business Office or the Marketing Representative. If service call is caused by customer-provided equipment, billing should be made in accordance with BSP 660-101-312.

3.15 Privacy—This option requires the installation of a D-180604 kit of parts at each station to be locked out.

(a) Install as follows:

- (1) Remove telephone set lower housing to obtain access to the amplifier printed wiring board.
- (2) Transfer leads from push-on terminals on amplifier board to those on privacy circuit board (Fig. 13). See Table D or wiring label on loudspeaker housing in set.
- (3) Mount privacy circuit board on the two bosses located under the front handset pocket with component side of board facing into the upper housing (Fig. 14).



Fig. 10—Faceplate Removal

- (4) Secure board using two screws furnished with kit of parts.
- (5) Replace lower housing.
- (b) ♦Test privacy feature as follows:
- (1) At a second station, go off-hook on an idle CO/PBX line.
 - (2) At the first station under test, go off-hook on same line. The first station should be locked out as evidenced by lack of sidetone.
 - (3) At the first station under test, select an idle line. Return to the line busied out by the second station by rapidly changing line buttons. The station should be locked out.
 - (4) Depressing the PRIV RLS button at the second station should permit the first station to bridge onto the busied-out line.
 - (5) If PRIV RLS button is not wired at second station, depress that station HOLD button. If the second station also has privacy kit installed, it will be locked out after depressing the HOLD button.



To avoid excluding oneself, a station with privacy kit installed must depress PRIV RLS button to allow conferencing.

- (c) Test privacy release as follows:
- (1) At station to be tested, go off-hook on an idle CO/PBX line to busy it out.

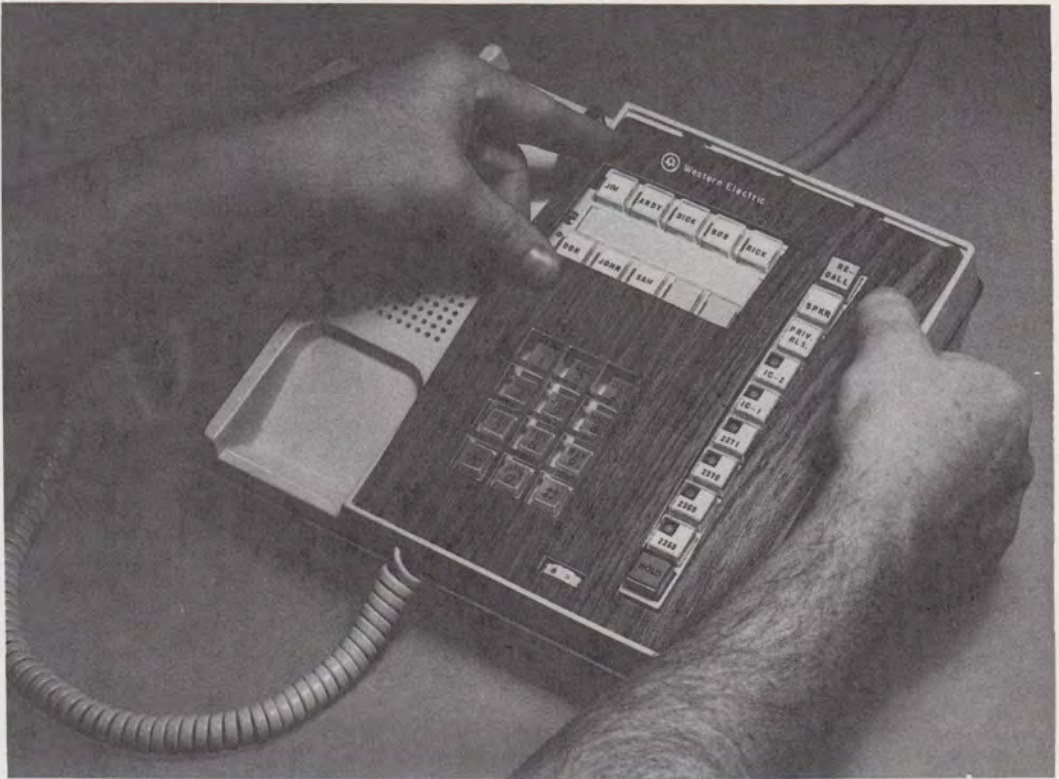

Fig. 11—Replacing Faceplate

(2) At second station equipped with a privacy circuit, go off-hook on the same line. No sidetone should be heard in this handset.

(3) At the first station, depress the PRIV RLS button momentarily. This should permit the second station to bridge onto the line.⚡

3.16 To disable SPKR:

(1) Remove faceplate by inserting a KS-16750 tool in the notch near the center of the faceplate and raising upward. See Fig. 10.

(2) Remove DSS key.

(3) Remove W-BR lead from telephone set terminal 9 and W-G from terminal 38. Insulate and store leads.

(4) Replace DSS key.

(5) Replace faceplate (see Fig. 11).

3.17 Install connector cables for system as required.

3.18 ⚡24A Apparatus Unit

(a) Install the 24A apparatus unit as follows:

(1) Remove the cover and mount the base pan assembly (Fig. 15) on the desired vertical location (use appropriate fastener per BSP 080-720-105).

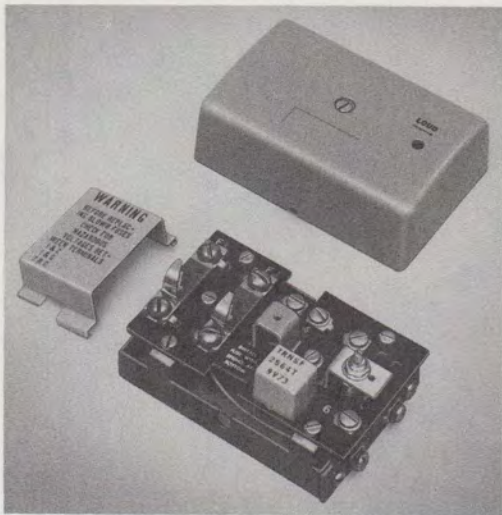

Fig. 12—33A Voice Coupler

TABLE C

33A VOICE COUPLER CONNECTIONS

33A VOICE COUPLER	91A CONN. BLOCK	CUSTOMER-PROVIDED MUSIC SOURCE
1		†
2		†
3	M	
4	M	
G*		

* Connect to approved local ground.

† Connections to be made by customer.

(2) Remove the cable clamp or clamps (Fig. 15).

(3) Insert system cable or cables (Fig. 15).

TABLE D

TO ADD PRIVACY OPTION

LEAD COLOR	REMOVE FROM	CONNECT TO
	AMPLIFIER TERMINAL	PRIVACY TERMINAL
BL	1	1
BK-G	2	2
G-W	3	3
Y-S	4	4
G	5	5
R-S	6	6
S-Y	7	7
R-O	8	8
W	9	9

(4) Replace the cable clamp or clamps using the tapped hole in the base pan or standoff to hold the cable securely.

(b) Connect the 24A apparatus unit as follows:

(1) The 24A is factory-wired (Fig. 29) to provide power failure ringer service for CO/PBX lines 1 and 2. To connect the unit to lines 3 and 4, see Table E.

(2) Replace the housing.

(c) Test as follows:

(1) Unplug the ac line cord of the primary set serving CO/PBX lines 1 and 2. From any set, dial CO/PBX line 1. The power failure ringer will ring. Repeat for CO/PBX line 2.

(2) Hang up the calling set.

(3) Plug the ac line cord back into the ac receptacle.

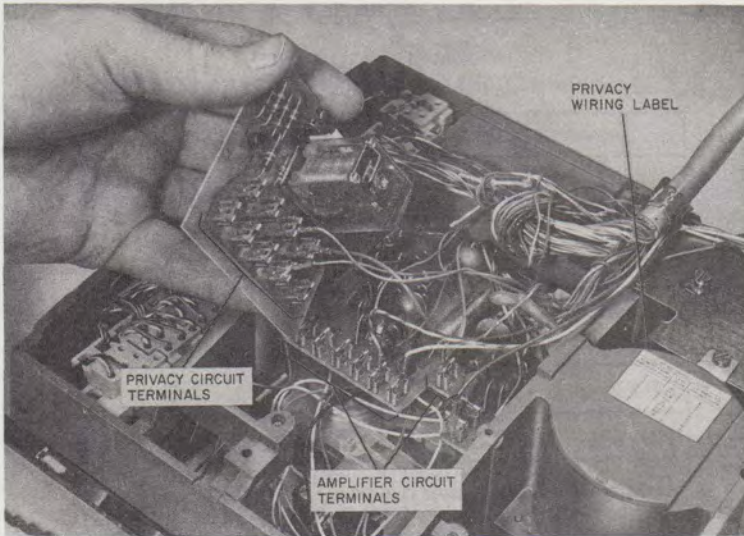

Fig. 13—Privacy Circuit Connections

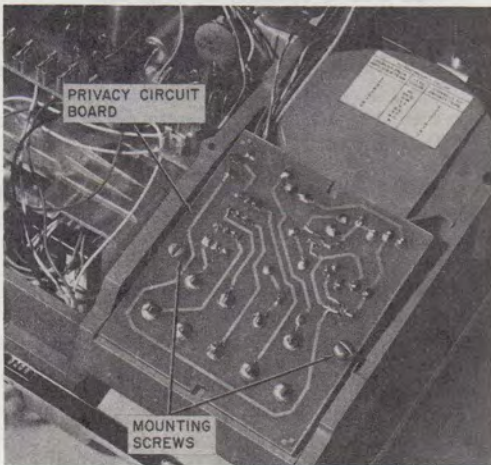

Fig. 14—Mounting Privacy Circuit

(4) From any set, dial CO/PBX line 1; then line 2. The power failure ringers should not ring.

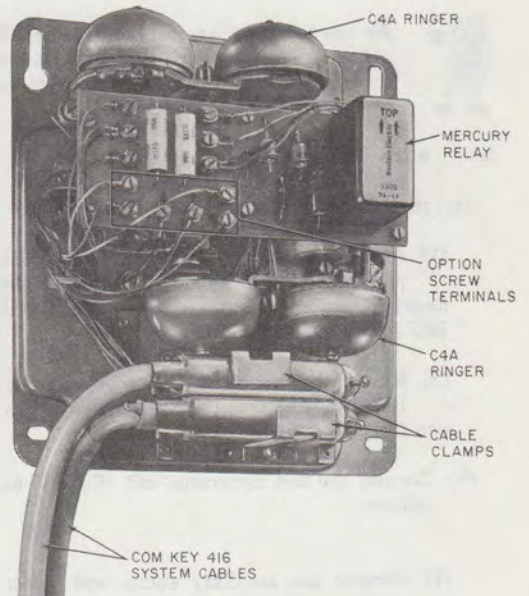

Fig. 15—24A Apparatus Unit

◆ TABLE E ◆

24A APPARATUS UNIT
(CONNECTIONS FOR CO/PBX LINES 3 AND 4 ONLY)

REMOVE LEAD FROM*		CONNECT LEAD TO†	
LEAD COLOR	PRINTED WIRING BOARD TERMINAL	LEAD COLOR	PRINTED WIRING BOARD TERMINAL
BL-W	5*	O-R	5
W-BL	4*	R-O	4
BK-S	6*	Y-G	6
W-BR	9*	R-S	9
BR-W	7*	S-R	7

* Insulate and store after removal.

† Leads are insulated and stored.

- (5) If a second 24A apparatus unit is connected, use the same procedure on CO/PBX lines 3 and 4.



Be certain the ac line cord of each primary set is securely plugged back into its receptacle after completing these tests.

3.19 ◆ 25A Apparatus Unit

- (a) Install the 25A apparatus unit as follows:

- (1) Remove the cover and mount the base pan assembly (Fig. 16 and 17) at the desired location (use appropriate fastener per BSP 080-720-105).
- (2) Mount the KS-16626 L12 relay set per BSP 463-120-100 or the KS-16301 L17 relay set per BSP 463-110-100.

- (b) Connect the 25A apparatus unit (Fig. 16) as follows:

- (1) Connect the auxiliary signal and power supply to KS-16626 L12 relay set and/or KS-16301 L17 relay set per BSP 463-120-100 or BSP 463-110-100, respectively.

- (2) If the auxiliary signal is to respond to any one DSS code, move the spade-tip lead associated with that code from terminals DSS 1-10 to terminal IN (Fig. 30).

- (3) If the auxiliary signal is to respond to any combination of common audible signals (CA 1-4), move the spade-tipped lead associated with that line and/or lines to the A through D terminals, respectively.

Note: The 25A apparatus unit may be coded to respond to both DSS codes and common audible signals.

- (4) Insert system cable or cables (Fig. 16).
- (5) Position inserts (Fig. 16) inside cover to hold cables securely when cover is replaced.
- (6) Replace cover.

- (c) Test as follows:

- (1) If the auxiliary signal is coded to respond to a DSS code, depress that DSS button at any station to operate the auxiliary signal. The signal will continue to operate as long as the button is depressed.

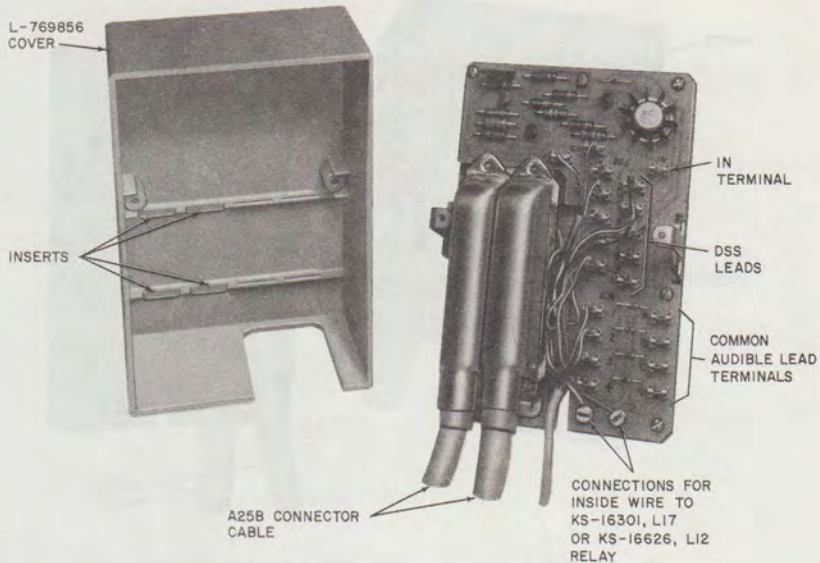

Fig. 16—25A Apparatus Unit

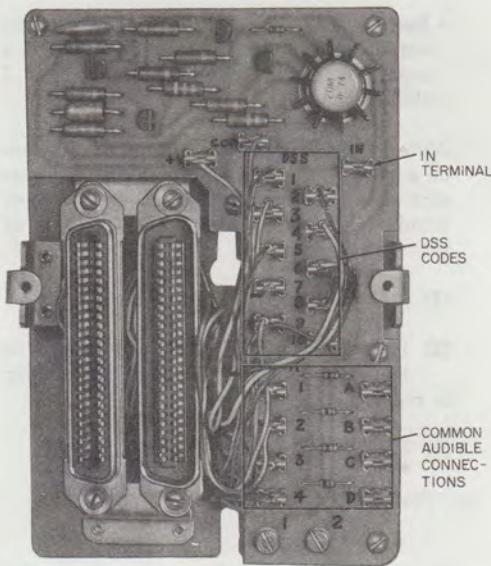

Fig. 17—25A Apparatus Unit Base

- (2) If the auxiliary signal is coded to respond to common audible signal(s), call each of these lines from a station. The auxiliary signal will follow the normal CO/PBX ringing pattern.

3.20 26A Apparatus Unit

- (a) Install the 26A apparatus unit as follows:

- (1) Remove the cover and mount the base assembly (Fig. 18 and 19) on the desired location (use appropriate fastener per BSP 080-720-105).

- (b) Connect the 26A apparatus unit (Fig. 19) as follows:

- (1) Determine which DSS code will be used to access the input for multiple signaling and which DSS codes are to be called simultaneously (Fig. 31) and connect as follows:

- Remove the lead corresponding to the input code from the numbered terminal (Fig. 19)

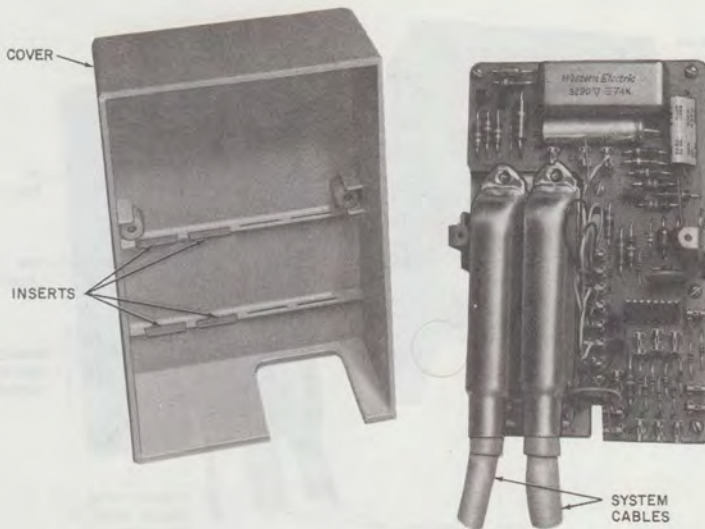

Fig. 18—26A Apparatus Unit With L-769856 Cover

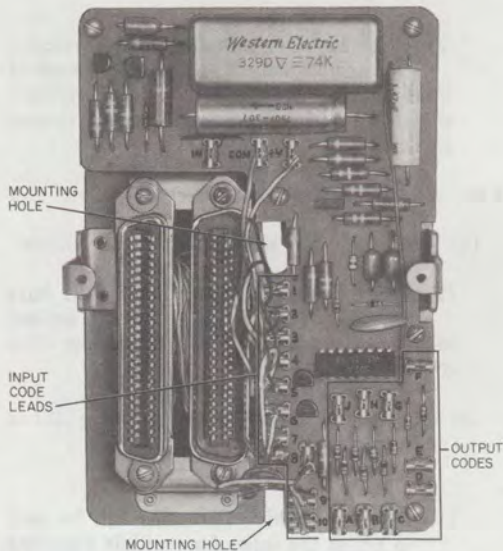

Fig. 19—26A Apparatus Unit Base

and 31) where it is stored; insert the lead in the IN terminal (Fig. 18 and 31).

- Remove the leads corresponding to the output codes and insert each lead in a separate terminal lettered A through J (Fig. 19 and 31).

Note: Selection of lettered terminals A-J are on a random basis, using only 1 DSS code per terminal. If possible, do not use adjacent terminals; this will prevent the possibility of shorted terminals.

- (2) Insert system cables (Fig. 18).
- (3) Position inserts (Fig. 18) inside cover to hold cables securely in place when cover is replaced.

- (4) Replace the cover.

(c) Test as follows:

- (1) At an idle telephone set, adjust the volume control to maximum and set the DSS selector switch to DSS code 1.

Note: The SPKR button must be in the released (up) position.

- (2) Select and depress an idle intercom (IC) line button. Depress and hold the DSS button corresponding to the input code of the 26A apparatus unit and speak into the handset. Speech shall be heard from the loudspeaker in the station set if the 26A apparatus unit is coded to access the zone coded in step (1).
- (3) Repeat steps (1) and (2), moving the DSS selector switch through the remaining DSS zones.⚡

3.21 ⚡27A Apparatus Unit

- (a) Install the 27A apparatus unit as follows:

- (1) Remove the cover and mount the base pan assembly (Fig. 20 and 21) in the desired location (use appropriate fasteners per BSP 080-720-103).
- (2) If background music is to be provided, install the 33A voice coupler per 3.14(b).

Note: Only one 33A voice coupler is required in the system to provide music to the 27A

apparatus unit, all 109A loudspeakers, and to the primary set(s) for music-on-hold.

- (b) Connect the 27A apparatus unit as follows:

- (1) Determine the DSS code that will be used to access the input of the paging system. Remove the lead corresponding to the input code from the numbered terminal (Fig. 32) where it is stored and insert the lead in the IN terminal (Fig. 32).
- (2) If music is provided, connect screw terminals 5 and 6 of the 33A voice coupler to screw terminals M1 and M2 (Fig. 21).
- (3) If the customer's paging system requires a contact closure when the paging occurs, connect the coil circuit of a KS-16626 L12 relay set per BSP 463-120-100 to screw terminals R1 and R2 of the 27A. Also connect a shorting strap between screw terminals R3 and R4.
- (4) Insert system cable or cables (Fig. 20).
- (5) Position inserts (Fig. 20) inside cover to hold cables securely when cover is replaced.

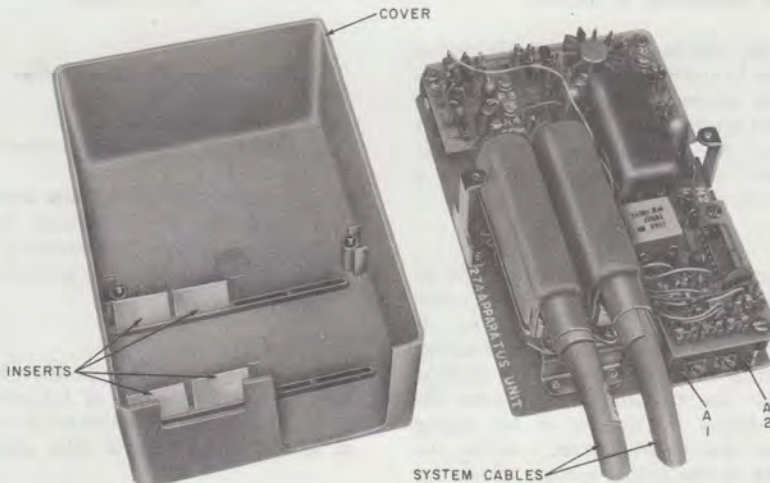

Fig. 20—⚡27A Apparatus Unit With L-769856 Cover⚡

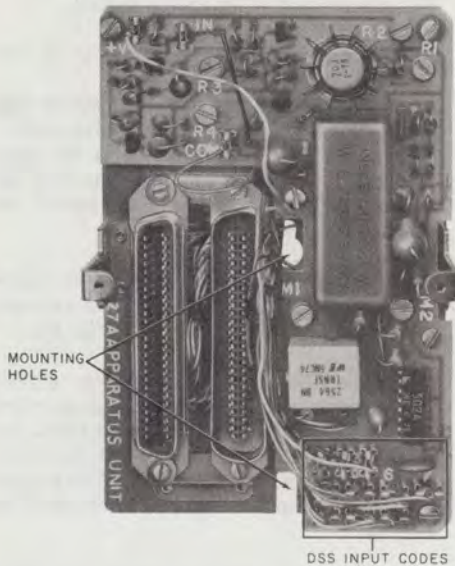

Fig. 21—27A Apparatus Unit

(6) Replace the cover.

(b) Test the installation as follows:

(1) Ask the customer to connect his paging system to screw terminals A1 and A2. If his paging system is not available, connect the red and green leads of a 107A loudspeaker to A1 and A2, respectively. Connect the yellow and brown leads of the 107A to a 2012B power transformer.

(2) At any telephone set, depress an idle IC button. Depress and hold the DSS button that corresponds to the paging system. If background music is provided, it will be muted. If an external relay was used, it will operate. Speak into the transmitter and have the customer adjust the volume of his paging system to the desired level. After the adjustment of the paging system volume for speech, the background music level may be varied by adjusting the potentiometer on the 33A voice coupler.



If music-on-hold was previously furnished, do not adjust the level from the customer-provided music source.

3.22 109A Loudspeaker Set (Fig. 22, 23, 24, and 33)

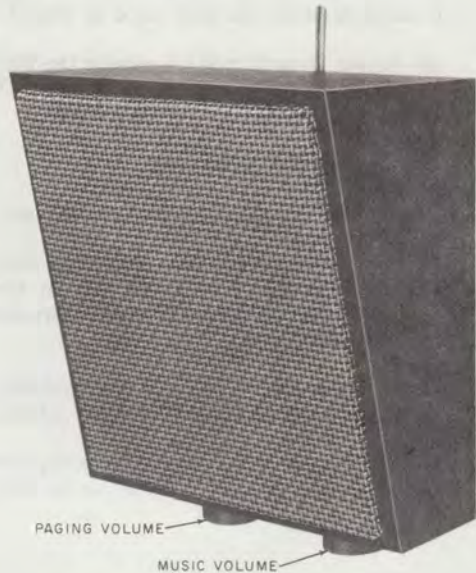

Fig. 22—109A Loudspeaker Set

(a) Install the 109A loudspeaker as follows:

(1) Mount the wall bracket assembly (Fig. 23 and 24) at the desired location. This assembly is mounted directly to a flat surface or an outlet box. Use appropriate fasteners per BSP 080-720-105.



For each loudspeaker installed, the total number of telephone sets per system (as covered in 3.02) must be reduced by a like number.

(2) If music is provided, install the 33A voice coupler as described in 3.14(b).

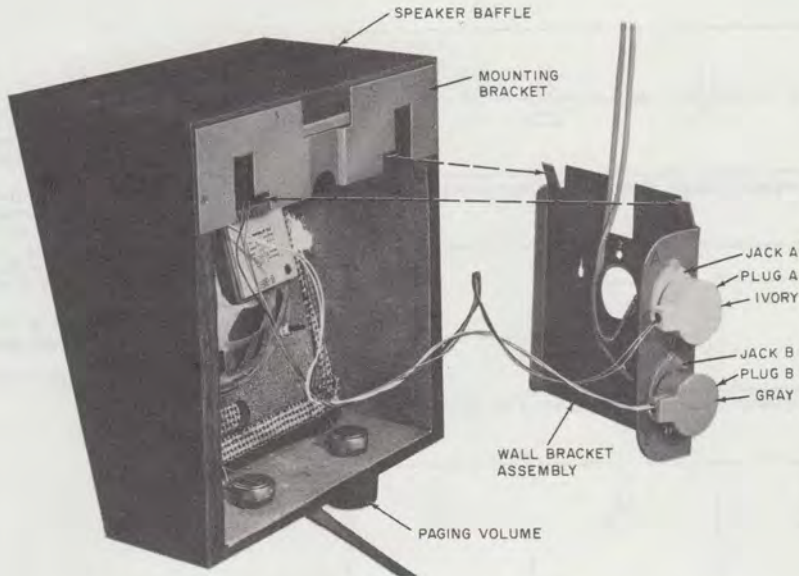

Fig. 23—109A Loudspeaker Set With Wall Bracket Assembly

Note: Only one 33A voice coupler is required in the system to provide music to all 109A loudspeakers and to the primary set(s) for music-on-hold.

(b) Connect 109A loudspeaker set as follows:

- (1) Connect +V, COM, and DSS to jack A (ivory) of the wall bracket assembly (Fig. 23) per Table F.
- (2) If music is provided, connect terminals 5 and 6 of the 33A voice coupler to terminals R and G of jack B (gray) of the wall bracket assembly (Fig. 23) using inside wire.
- (3) Connect plug A of loudspeaker into jack A of wall bracket assembly and plug B into jack B, ivory to ivory and gray to gray, respectively (Fig. 23).
- (4) Slip the speaker baffle mounting bracket over the mounting clips on the wall bracket assembly and pull the speaker down until it is firmly held (Fig. 23).

(c) If background music is provided, adjust the volume control of the 33A voice coupler to mid-range; then adjust the right-hand volume control(s) on the loudspeaker(s) to the desired music level (Fig. 22). The volume control of the 33A voice coupler may be readjusted, if necessary, to raise or lower the overall music level.



If music-on-hold was previously furnished, do not adjust the level from the customer-provided music source.

(d) Test the loudspeaker as follows:

- (1) At any telephone set, depress an idle IC button and the DSS button that corresponds to the 109A loudspeaker set (if background music is provided it will be muted). Speak into the transmitter and adjust the volume control to the level desired by the customer (Fig. 22).

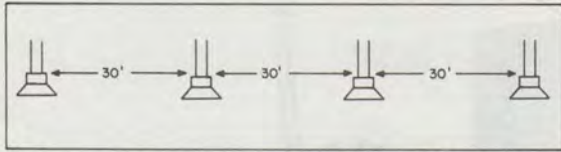

EXAMPLE A - SPEAKERS LOCATED ON ONE WALL OF ROOM (NOTES 1, 2 AND 3)

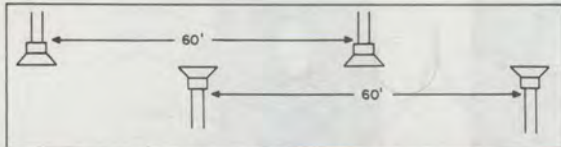

EXAMPLE B - SPEAKERS LOCATED ON OPPOSITE WALLS OF ROOM (NOTES 1 AND 2)

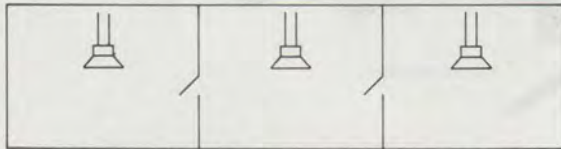

EXAMPLE C - SPEAKERS LOCATED IN INDIVIDUAL ROOMS (NOTES 1, 2 AND 4)

NOTES:

1. EXAMPLES A, B AND C ARE FOR QUIET OR OFFICE TYPE ENVIRONMENTS. FOR A NOISY ENVIRONMENT, DISTANCE BETWEEN SPEAKERS MUST BE REDUCED TO A DISTANCE THAT WILL PROVIDE THE SAME LISTENING LEVEL. ALL SPEAKERS SHOULD BE LOCATED AT LEAST 60 FEET FROM ANY STATION USED FOR PAGING.
2. SPEAKER WIRING SHOULD BE RUN SEPARATELY, NOT PART OF A VOICE CABLE. QUAD CABLE SHOULD BE USED WITH BOTH PAIRS CONNECTED. SPEAKERS SHOULD BE HUNG AS CLOSE TO THE CEILING AS POSSIBLE.
3. SPEAKERS REACH A DEPTH OF 30 FT. IF ROOM IS OVER 30 FT. WIDE, FACING SPEAKERS SHOULD BE USED.
4. ONE SPEAKER WILL SERVE A ROOM UP TO 25 FT. BY 25 FT.

Fig. 24—Example of 109A Loudspeaker Locations



If music-on-hold was previously furnished, do not adjust the level from the customer-provided music source. However, once the customer's paging system level has been set, the level of the background music may be altered by adjusting the screwdriver accessible potentiometer on the 33A voice coupler.

4. CONNECTIONS

- 4.01 Terminate the incoming CO/PBX lines on the 91A connecting block(s) associated with the primary station(s). See Table G.
- 4.02 Connect primary station line cords to customer-provided ac power.
- 4.03 Wiring schematics for 836-, 2836-, 837-, and 2837-type telephone sets are furnished in Fig. 25 through 28.

5. METHOD OF OPERATION

ANSWERING CALLS

5.01 *Incoming Call on CO/PBX Line*—When audible tone signal sounds and lamp associated with CO/PBX button flashes, answer call as follows:

- (1) Lift handset (line buttons will not lock down unless handset is off-hook).
- (2) Depress CO/PBX button associated with flashing lamp—audible signal is silenced and lamp under CO/PBX button goes steady.
- (3) Answer call.

Note: The level of incoming voice signaling or tone ringing will be reduced while off-hook.

5.02 *Intercom Call*—When voice signal is heard:

- (1) Calling party will tell you what action to take (if any).

◆ TABLE F ◆

**109A LOUDSPEAKER SET
CONNECTIONS TO JACK A (IVORY)**

FUNCTION OF LEAD IN COM KEY 416 CABLE	CONNECT (NOTE 1)		
	FROM	TO	
	JACK A (IVORY)	91A CONN BLOCK (SEE NOTES 2 & 4)	STD CUTDOWN ON 66-TYPE CONN BLOCK (OPTIONAL)
+V	R	45	Y-S
COM	B	20	S-Y
DSS (See Note 3)	G	D1	BR-BK
		D2	BK-BR
		D3	O-Y
		D4	Y-O
		D5	BR-Y
		D6	Y-BR
		D7	BL-V
		D8	V-BL
		D9	O-V
		D10	V-O

Note 1: Use inside wire to make connections.

Note 2: Short the four physically adjacent terminals 20, M, R1, and R2 and short the four physically adjacent terminals T2, T1, M, and 45.

Note 3: Connection is made to one of the DSS zones D1–D10 as appropriate.

Note 4: If connections are made to the 91A connecting block serving either primary set, the shorts of Note 2 are not required.

TABLE G

CO/PBX LINE CONNECTIONS

LEAD DESIG.	AT 1st PRIMARY STATION	AT 2nd PRIMARY STATION
	91A CONN. BLOCK	91A CONN. BLOCK
R(1)	R1	
T(1)	T1	
R(2)	R2	
T(2)	T2	
R(3)		R1
T(3)		T1
R(4)		R2
T(4)		T2

- (2) If necessary, lift handset and depress intercom button as per instructions to converse with calling party.

PLACING CALLS

5.03 *Outgoing Call*—To make an outgoing call:

- (1) Lift handset.
- (2) Depress CO/PBX button associated with an idle line.
- (3) Dial number when dial tone is received.

5.04 *Intercom Call*—To make an intercom call:

- (1) Lift handset.
- (2) Select idle intercom path and depress button. No dial tone is provided on intercom.
- (3) Depress and hold button on DSS key corresponding to desired station that is to receive voice message. Multiple stations may be signaled by depressing more than one DSS button at a time, or the preset multiple voice signaling option may be used. Give message to called party. ***DSS button must be held depressed during entire one-way conversation.***

- (4) Release button when one-way message is completed.

- (5) To carry on a 2-way conversation, the called party must pick up handset and depress the same intercom button on his set being used by the calling party.

5.05 *Multiple CO/PBX Conferencing*

- (a) To conference CO/PBX lines:

- (1) Make outgoing call (5.03) to desired party.
- (2) Depress HOLD button; line button will restore and go on hold.
- (3) Make outgoing call on another idle CO/PBX line.
- (4) While holding the second CO/PBX line button down, depress the first held line button.
- (5) Additional parties may be added by repeating the above procedure.

Note: Since no amplification is provided, this type of conferencing is limited. When lines are conferenced using this manner of conferencing, distant stations may have trouble hearing each other and transmission is not guaranteed. All lines that are conferenced together may be put on hold simultaneously by depressing the HOLD button.

- (b) To make a call during a conference:

- (1) Depress HOLD button—all buttons restore and lines go on hold.
- (2) Select an idle line.
- (3) Dial call.
- (4) To reenter conference again after call is completed, simultaneously depress conferenced buttons again.
- (5) If it is desired to add this call to the conference, hold this CO/PBX line button down and depress the conferenced CO/PBX line buttons.

(6) If it is desired to add another call to the conference, hold the conferenced CO/PBX line buttons down and depress button of CO/PBX line to be added.

(7) To prevent dropping one of the participants when setting up a conference, ensure that the conferenced CO/PBX line buttons are held down when adding another station.



Intercom and CO/PBX lines cannot be conferenced together.

5.06 Privacy, Privacy Release

(a) To bring a locked-out station into a conversation, depress the PRIV RLS button. The line will go on hold with the lamp winking. The button must be held depressed until the locked-out party bridges onto the line at which time the lamp goes steady. The button should then be released.

(b) To add a station equipped with privacy to a bridged conference, all of the sets already connected must depress their PRIV RLS button to allow the station to bridge onto the conference.

5.07 Built-in Loudspeaker Service—To use, depress button on line key designated SPKR. When conversation is finished, depress button to release SPKR before replacing handset. Otherwise, a feedback “squeal” may be heard as the handset is brought near the speaker.



Incoming voice and tone signaling will not be attenuated in the off-hook condition if the SPKR button is locked down. This button is not linked to the ABR mechanism.

6. MAINTENANCE

6.01 Maintenance of the 4A System is limited to making wiring checks, replacement of telephone sets, or those set components covered in this section. DO NOT attempt to modify or repair telephone sets or apparatus units in a manner other than covered.

6.02 When trouble is encountered, ***first make a thorough check of all connections***, then

make the following checks before repair or replacement of telephone sets is considered.

- Primary station power cord is connected to a working ac receptacle.
- Primary station transformer(s) is securely in place.
- Sets are securely connected to adapters.
- Volume control is not turned all the way down.
- Lamps are not burned out.
- Incoming CO/PBX pairs are securely terminated on 91A connecting blocks associated with primary stations.
- Plugs are secure on line key.

6.03 If more than one set has the same trouble, the trouble is usually in a primary station set. In multiple primary set installations (three and four CO/PBX lines), the trouble can be further isolated by unplugging one primary set and observing operation of the remaining primary set. If service provided by the disabled primary set does not restore to normal when the power cord is reconnected, that primary set is defective.

6.04 If normal service is provided on at least one set but not on any other set, the problem is probably in the cabling. If all sets beyond a point on the cable bus relative to a primary set exhibit the same trouble, the cable fault is an open conductor path. If all sets exhibit the same trouble and service can be restored to sets near a primary set by disconnecting the cable bus beyond that point, the fault is a conductor short.

6.05 Diagnostic Table H contains information to assist in troubleshooting the system.

Dial Replacement

6.06 Replace rotary or TOUCH-TONE dial as follows:

- (1) Remove faceplate (see 3.13).
- (2) Remove DSS key (do not disconnect leads).

TABLE H
DIAGNOSTIC TABLE

TROUBLE	POSSIBLE CAUSES	POSSIBLE SOLUTIONS
One set does not ring on specified line(s) but lamp flashes properly.	Common audible switches not set properly.	Set the four common audible switches for desired ringing at that station.
One set does not receive voice signal on DSS.	Station designation not coded properly on DSS key.	Check for correct position of slide switch. Be sure switch is properly engaged in a detent (centered on number).
Low volume on ringing or voice signaling.	Volume control set too low. Handset off-hook.	Readjust volume. Replace handset.
One lamp does not light on one station but lights on other stations.	Lamp failure.	Replace lamp per 6.12.
A lamp does not light at any station and there is an audible buzz on the line associated with lamp.	Lamp pair shorted in a station or transposed on a connecting block.	Correct wiring.
No music-on-hold.	Blown fuse on 33A voice coupler, improper wiring of music-on-hold option.	Replace fuse. Check wiring of music-on-hold circuit board and 33A coupler.
Excessive crosstalk on lines 1 and 2 or 3 and 4 when on hold.	Improper installation of music-on-hold option.	1. Check wiring of 33A coupler. 2. Music-on-hold board installed in a set, but option not being furnished.
Music distorted or too low.	Improper adjustment of music level; customer's music source does not have sufficient output.	See 3.14.
Cannot drop a particular line at any station.	Failure of primary set logic circuit.	Replace primary set.
False hold condition when changing lines or lightly touching line buttons.	Defective line key.	Replace line key per 6.09.

(3) Remove and retain two screws holding dial in set.

(5) Transfer dial mounting brackets to new dial.

(4) Disconnect dial leads.

(6) Connect dial leads and replace dial in set using screws removed in (2).

TABLE H (Cont)

DIAGNOSTIC TABLE

TROUBLE	POSSIBLE CAUSES	POSSIBLE SOLUTIONS
No sidetone on CO/PBX line.	Incoming CO/PBX line is dead.	Check incoming tip and ring with test set.
	Incoming tip and ring terminated on wrong terminals.	Check connections.
	Switch pileup on telephone set is defective.	Change out telephone set.
	Privacy circuit (if set is so equipped) may be operating incorrectly.	Check to see if privacy relay is falsely operating when going off-hook. If yes, check connections. If okay, replace privacy circuit.
	If rotary dial set has dial restriction.	BL-R lead of telephone set not moved from terminal 28 to 39.
	If 66-type connecting blocks are used, the cutdown may be incorrect.	Check station cutdown.
	Set has privacy circuit and CO/PBX line is in use by another station.	No corrective action; wait until line is not in use.
All four CO/PBX lamps light dim; noise on intercom on all sets.	System power supply shorted.	Disconnect sets (one at a time). If problem persists, check cable.
Sidetone on CO/PBX lines; but no lamps on CO/PBX or intercom lines, no ringing on above lines, no intercom talk battery. Transformer usually warm.	No power applied to associated control set.	Verify power at ac outlet and ensure that sets are plugged in.
	Power supply was shorted long enough to permit thermal cutout in transformer to operate.	<ol style="list-style-type: none"> 1. Replace transformer. 2. Replace primary set. 3. Wait (up to 30 minutes) for thermal circuit breaker to reset automatically.
Cannot dial.	Set wired for dial restriction option.	No corrective action necessary.
Noise from speaker as volume control is rotated.	Defective volume control.	Replace assembly as covered in 6.13.

◆ TABLE H (Cont) ◆

DIAGNOSTIC TABLE

TROUBLE	POSSIBLE CAUSES	POSSIBLE SOLUTIONS
System wired for 3 or 4 CO/PBX lines, but only dial tone on lines 1 and 2. Cannot rotary dial on lines 1 and 2.	Line assignment connector not rotated.	Rotate line assignment connector as covered in 3.08.
Privacy circuit does not prevent pickup when going off-hook on a busy line.	Improperly wired or defective privacy circuit.	Correct wiring or replace privacy circuit.
Privacy circuit does not prevent pickup on busy line when rapidly changing lines, but is okay going off-hook.	Defective line key.	Replace line key.

(7) Replace DSS key.

(8) Test dial.

(9) Replace faceplate.

(5) Reset No. 1 switch to proper position and close cover.

Handset and Cord

6.07 The handset cord is equipped with standard modular set plugs. To remove cord from the set or handset, release catch by depressing with finger or KS-16750 tool. When reinserting plugs, make sure cord is locked in place.

DSS Key Cover Replacement

6.08 Replace cover as follows:

- (1) Raise cover perpendicular to key.
- (2) Move the No. 1 common audible switch to OFF.
- (3) Twist the cover clockwise and snap out.
- (4) Install new cover, twisting in the reverse direction.

Replacement of Line (647M6) Key

6.09 To replace the 10-button line key:

- (1) Remove faceplate and key collar.
- (2) Loosen key mounting screws at both ends of key and carefully lift key out of set.
- (3) Unplug all 508-type plugs from defective key.
- (4) Connect plugs to replacement key in the following order starting with the HOLD key: pink, blue, orange, green, brown, slate, white, red, black, yellow, and beige.

Note: Check that each plug is held in place by the matching locking tabs on the key body.

- (5) Replace key in its mounting **making sure that the key latch bar hook properly engages the telephone set ABR pivot bar.**

(6) Check that the wiring will not interfere with contact or button operation and tighten the key mounting screws.

6.10 Any time the line key has been removed or replaced, the following functional tests and necessary adjustments should be made:

(1) With the set plugged in, check the ABR on each CO/PBX line by going off-hook, depressing and locking the line button and gently replacing handset. The associated lamp should light while off-hook and the button restore when handset is replaced.

(2) Go off-hook, simultaneously lock down all four line buttons, and gently restore the handset. All buttons should release. Repeat for intercom buttons.

(3) Depress and lock one of the working CO/PBX line buttons and note that lamp is steady. Very slowly depress any of the other line buttons until the first button is released. If the first line goes on hold as indicated by the steady lamp changing to wink, the key is defective and should be replaced. Make this test for each working line.

(4) With handset on-hook, completely depress each line and intercom button one at a time. The associated lamp should not light. If any of the lamps light, adjust the ABR by loosening the screw on the ABR bracket in the upper left-hand corner of the faceplate opening. Move the bracket slightly toward the front of the telephone set. Tighten the screw and repeat above test.

6.11 After all tests and adjustments have been made, replace key collar and install faceplate (Fig. 11).

Lamp Assembly Replacement

6.12 If the lamp is defective, the button assembly must be replaced as follows:

(1) Remove faceplate and key collar.

(2) Pinch the button assembly between the thumb and forefinger at the second joint.

(3) Firmly but gently tilt the button to one side with the thumb until it snaps free from the plunger. Still holding the button slightly tilted, withdraw it from the lamp socket.

(4) Orient new button assembly so that lamp is in upper left corner of the button when viewed from front of set. Place button over lamp socket, gently slide it into the opening, and push on top until it snaps into place.

Volume Control

6.13 Replace potentiometer assembly as follows:

(1) Remove faceplate.

(2) Remove DSS key. Do not disconnect leads.

(3) Remove one screw holding assembly to base and disconnect leads from terminal field.

(4) Install assembly in reverse order.

Transformer

6.14 The transformer is removed as covered in 3.08(1). When installing transformer, make sure plug is properly engaged.

♦Apparatus Units

6.15 Maintenance of the apparatus units is limited to checking for loose connection. DO NOT attempt to repair the apparatus units in the field. If after checking for loose connections the unit will not function, replace the entire unit.♦

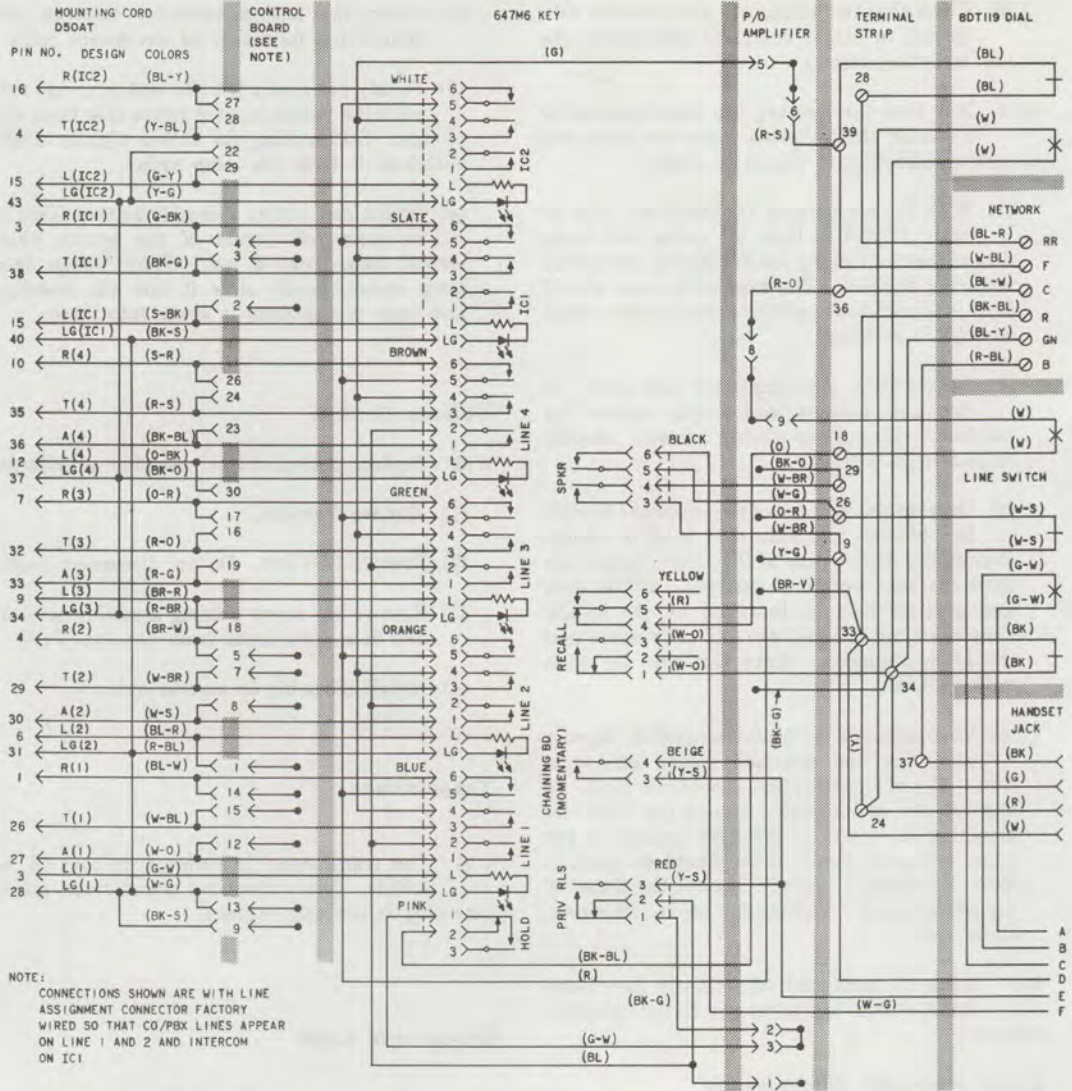

Fig. 25—Schematic, 836AM Telephone Set (Rotary Primary Station) (Sheet 1 of 2)

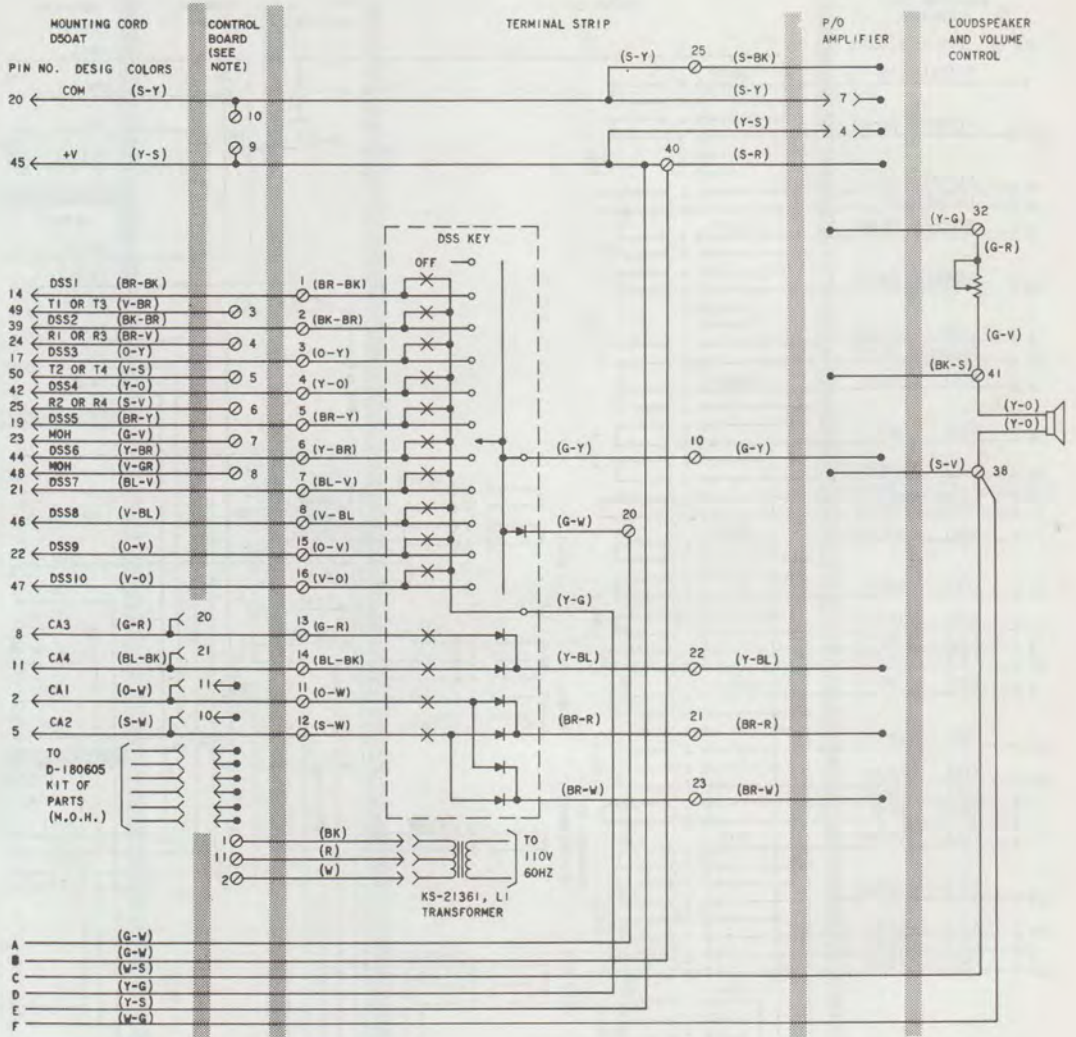

Fig. 25—Schematic, 836AM Telephone Set (Rotary Primary Station) (Sheet 2 of 2)

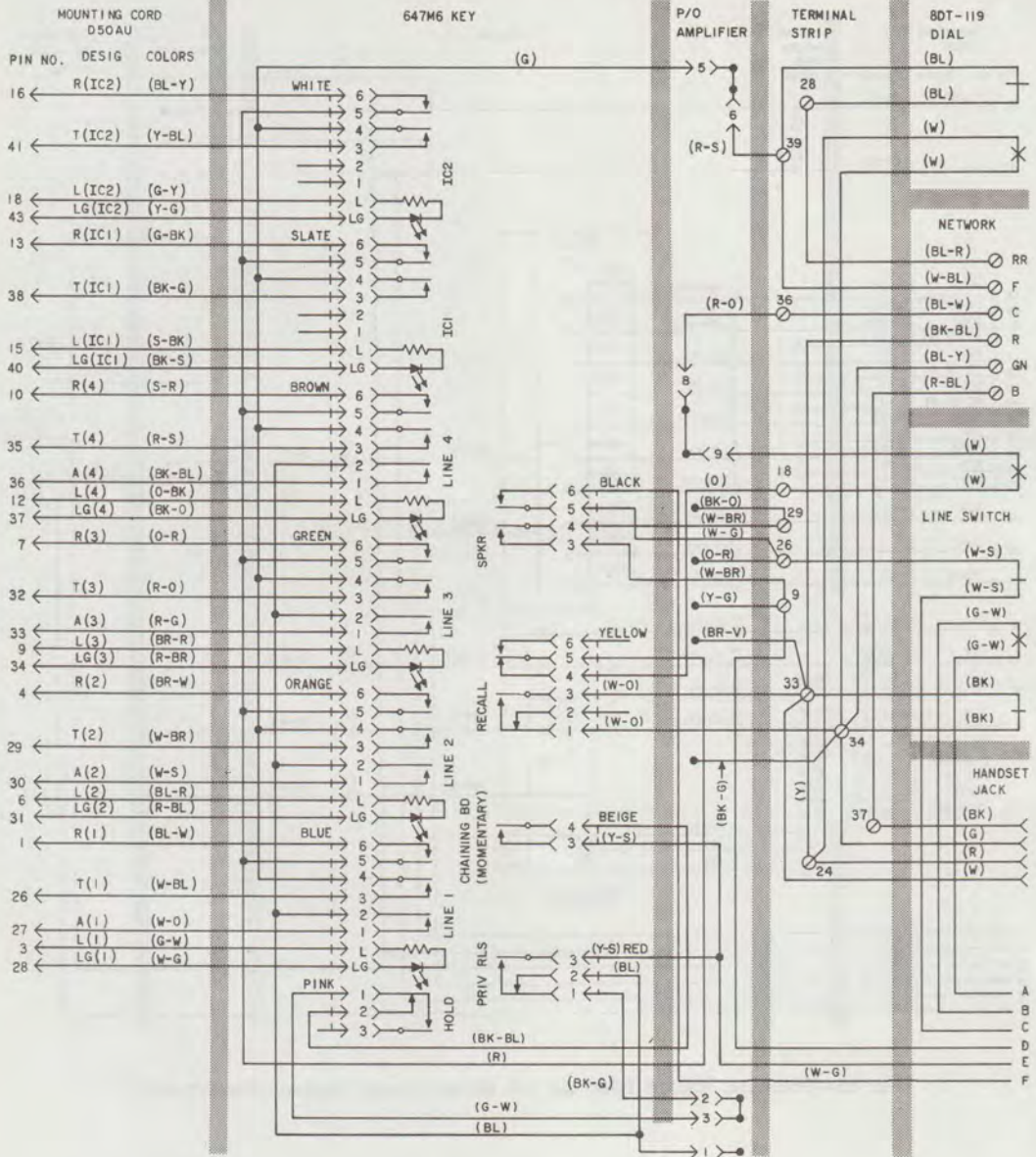

Fig. 26—Schematic, 837AM Telephone Set (Rotary Satellite Station) (Sheet 1 of 2)

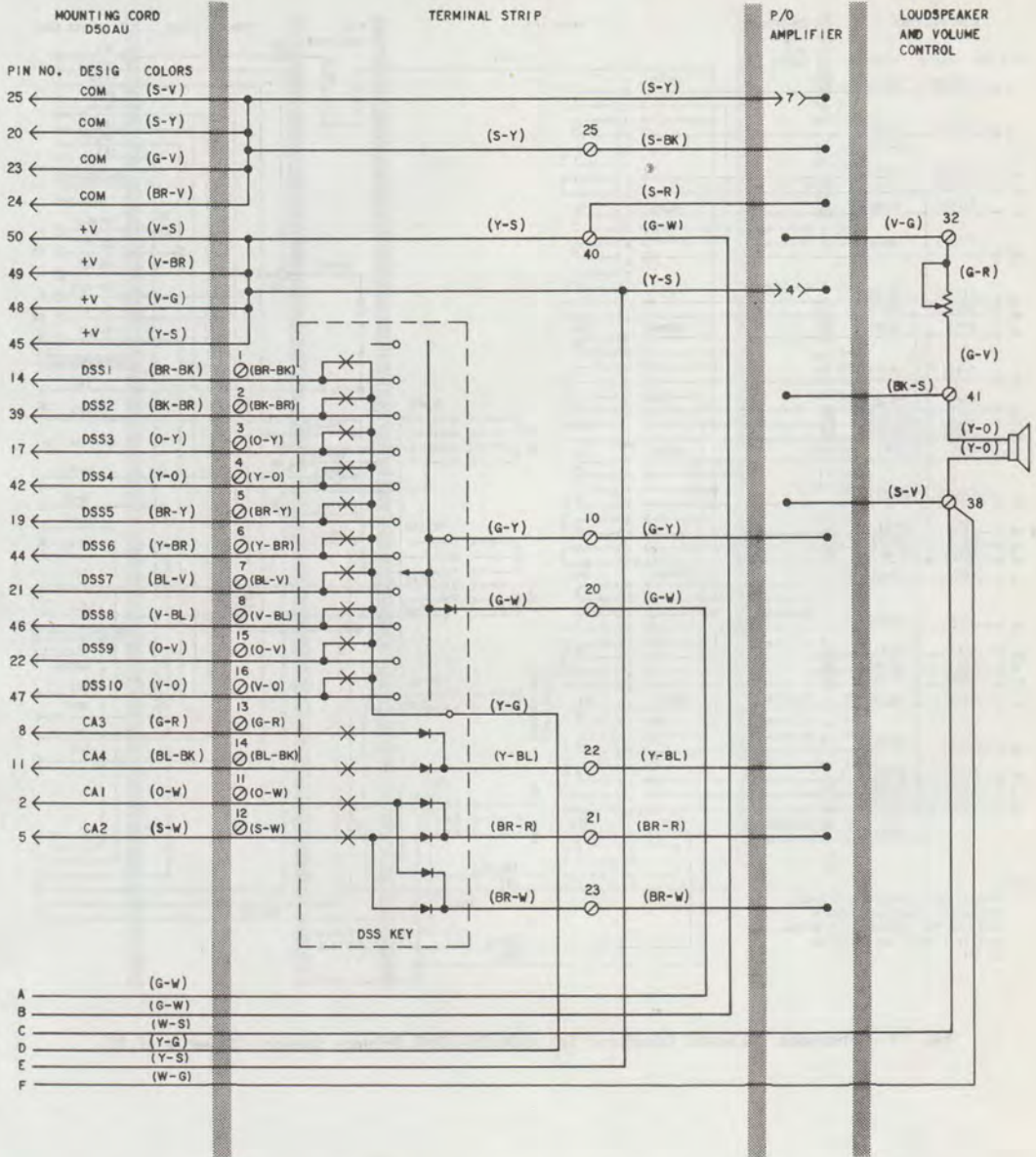

Fig. 26—Schematic, 837AM Telephone Set (Rotary Satellite Station) (Sheet 2 of 2)

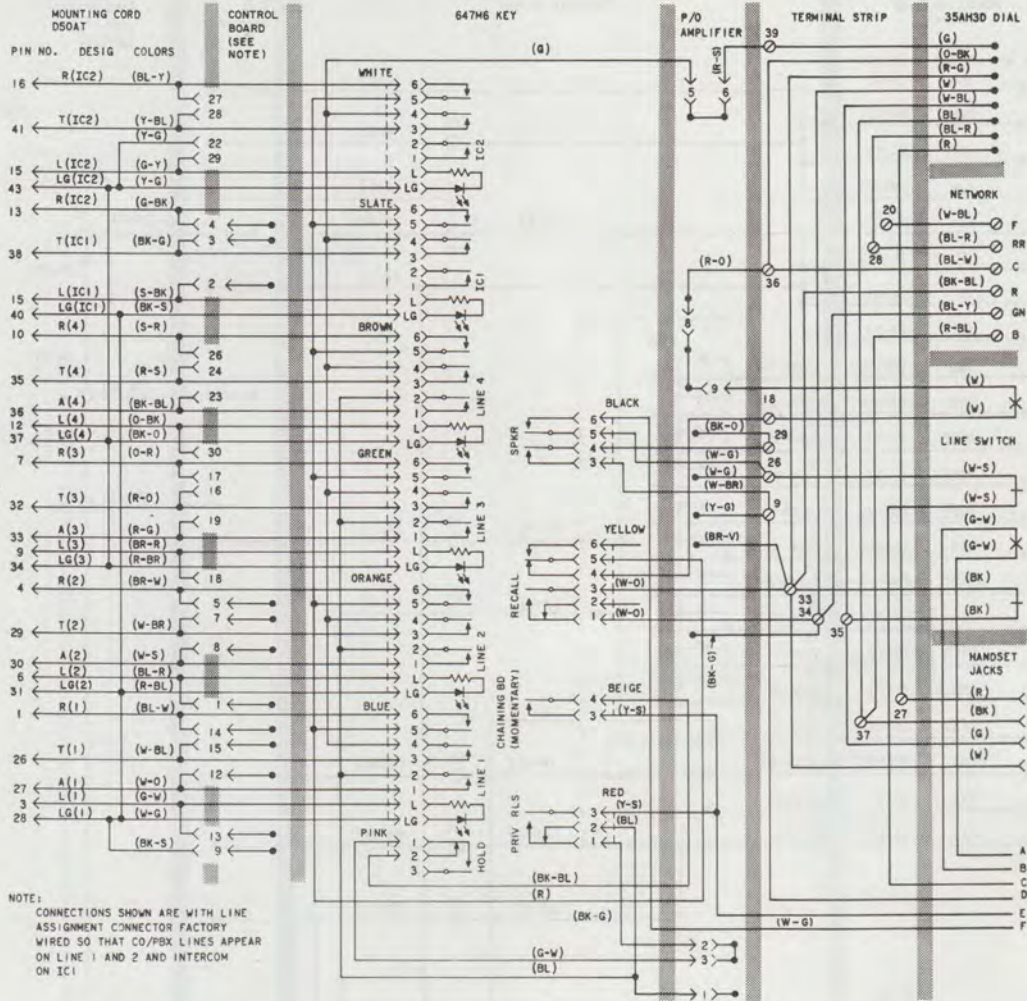

Fig. 27—Schematic, 2836AM Telephone Set (TOUCH-TONE Primary Station) (Sheet 1 of 2)

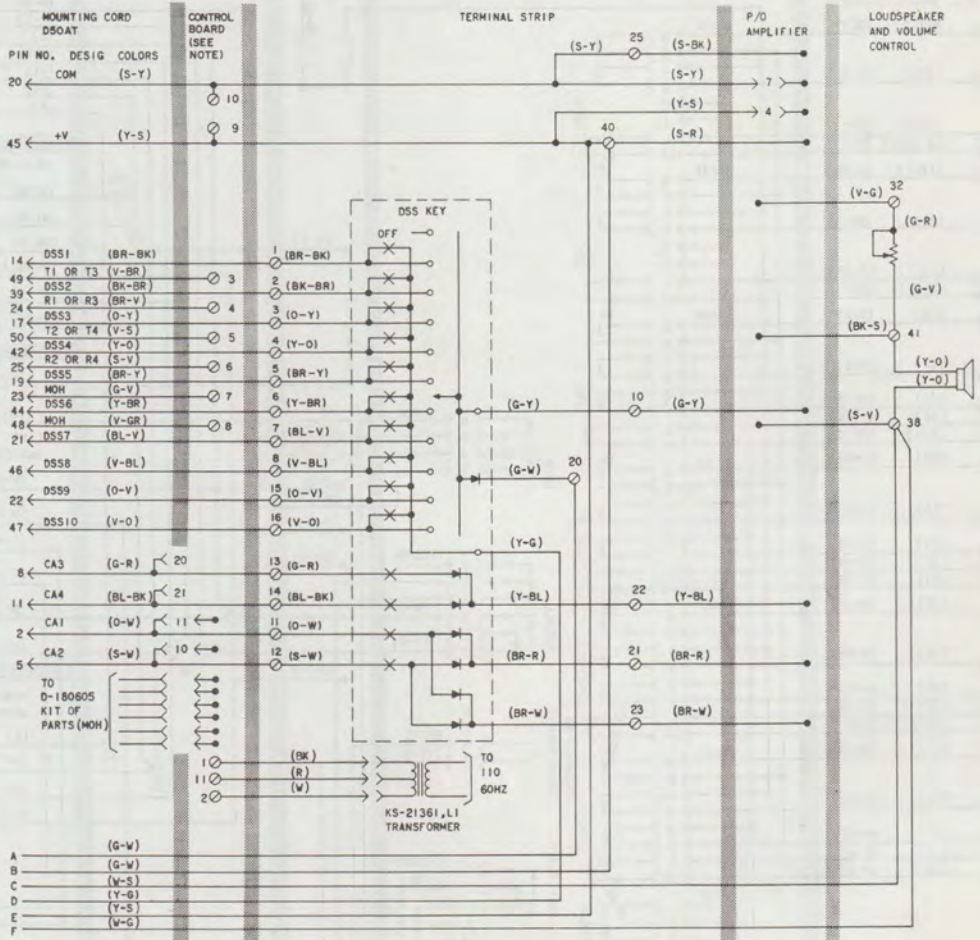

Fig. 27—Schematic, 2836AM Telephone Set (TOUCH-TONE Primary Station) (Sheet 2 of 2)

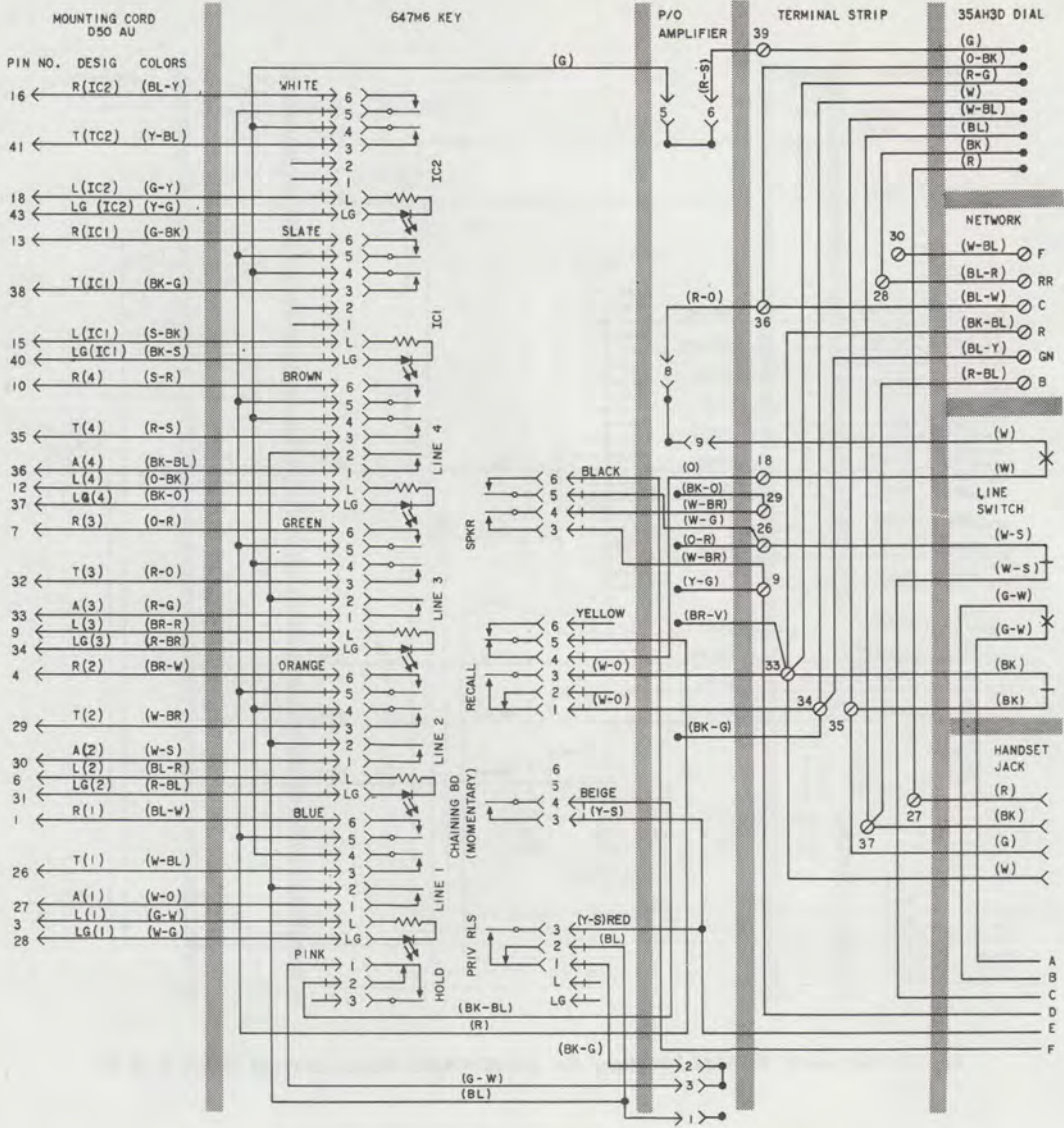

Fig. 28—Schematic, 2837AM Telephone Set (TOUCH-TONE Satellite Station) (Sheet 1 of 2)

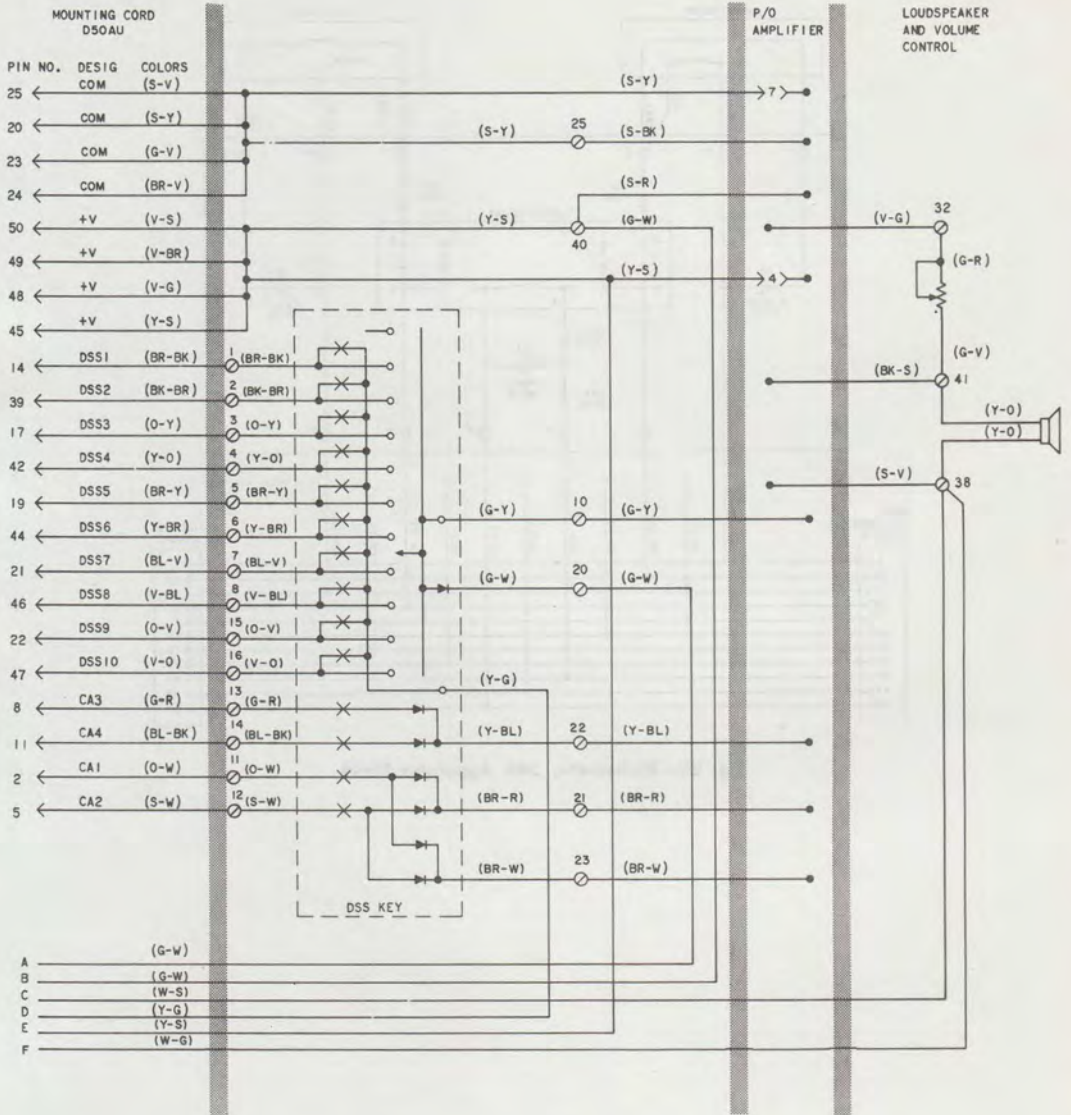

Fig. 28—Schematic, 2837AM Telephone Set (TOUCH-TONE Satellite Station) (Sheet 2 of 2)

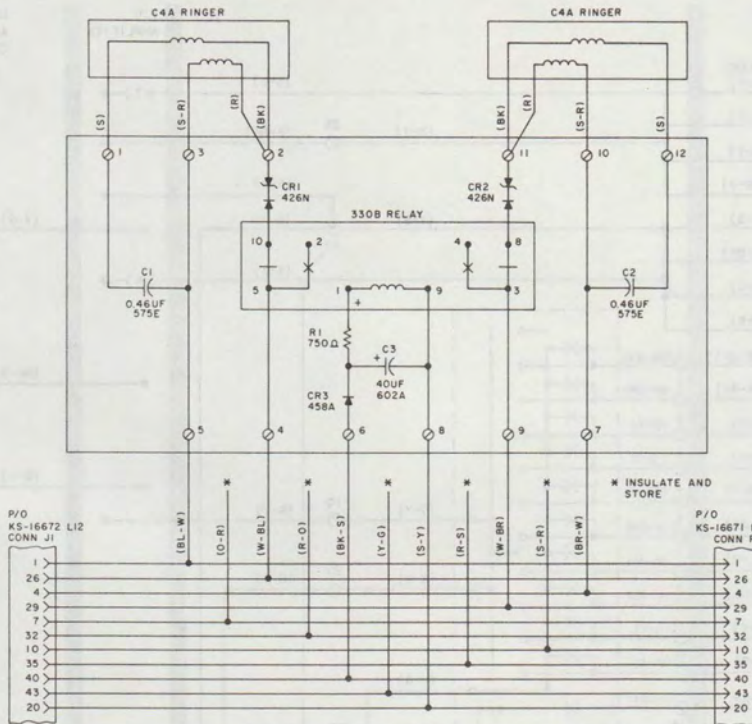

Fig. 29—Schematic, 24A Apparatus Unit

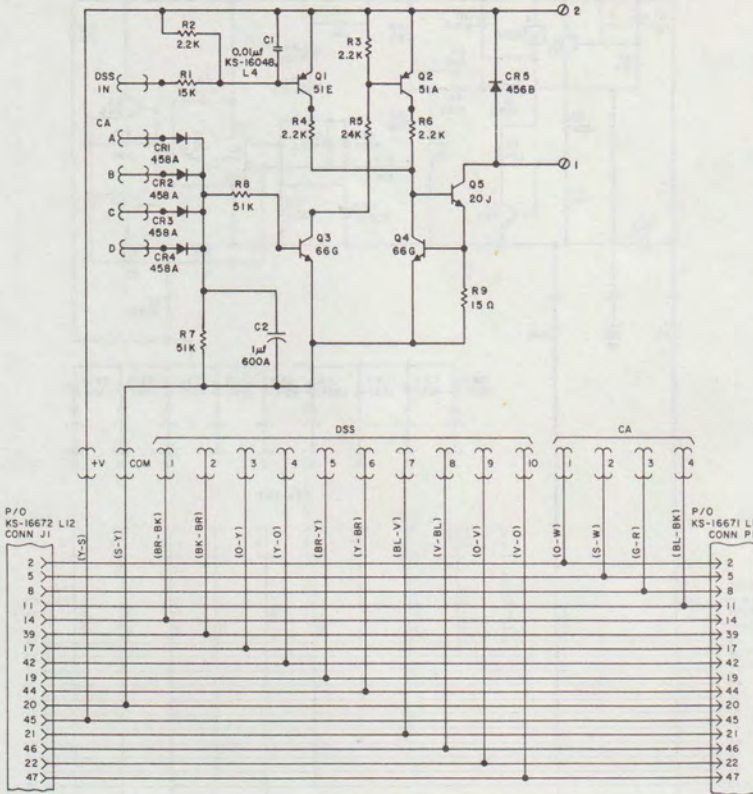

Fig. 30—Schematic, 25A Apparatus Unit

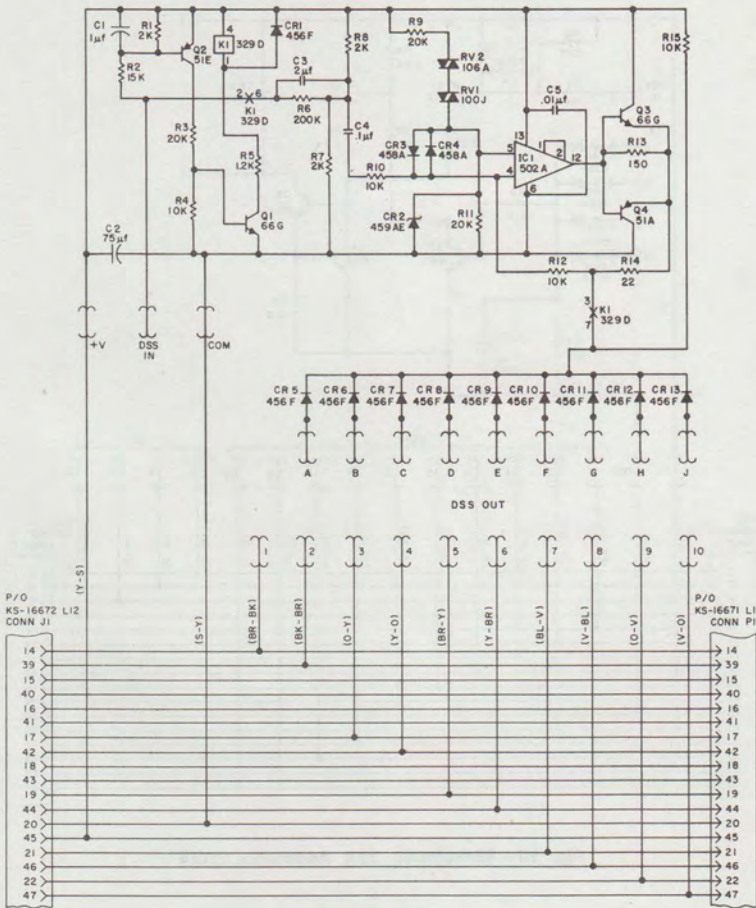

Fig. 31—Schematic, 26A Apparatus Unit

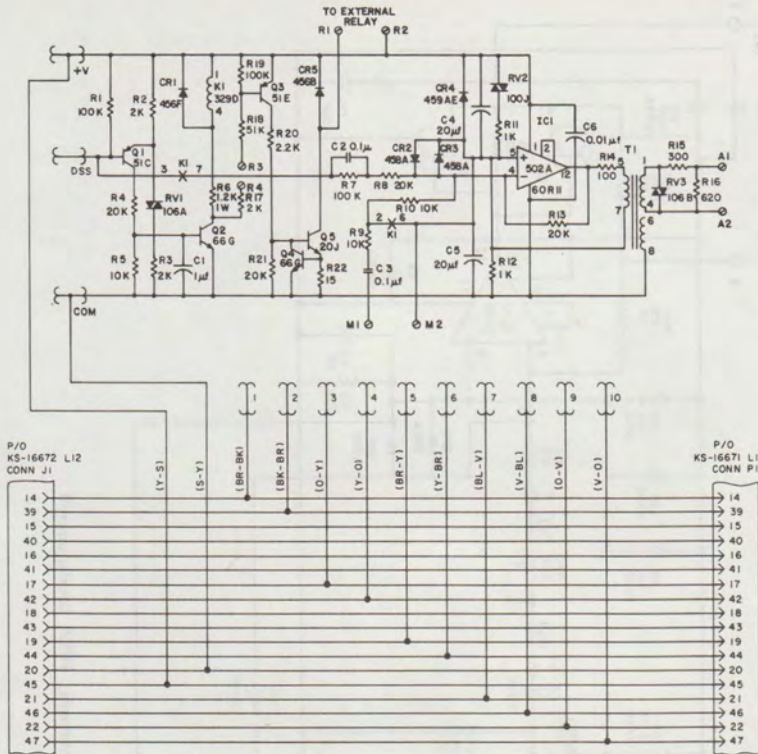

Fig. 32—Schematic, 27A Apparatus Unit

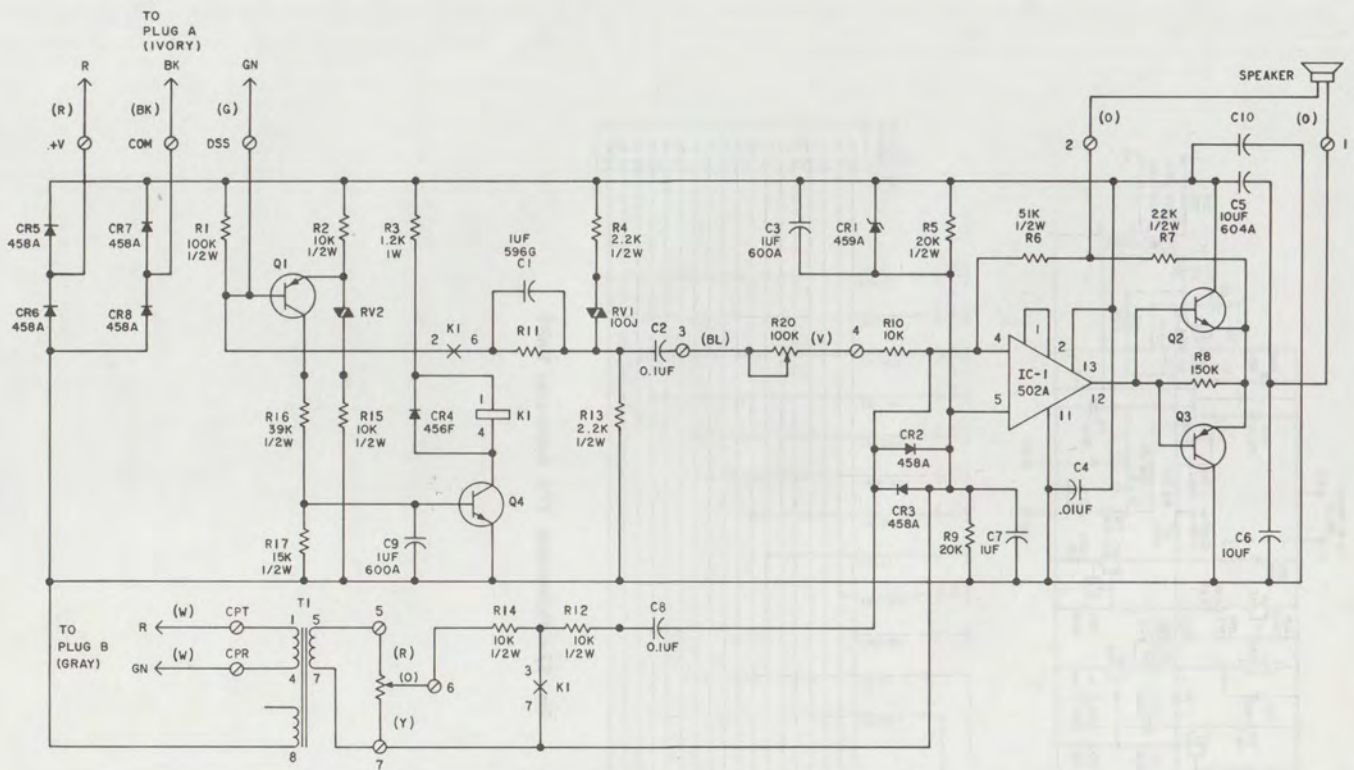

Fig. 33—Schematic, 109A Loudspeaker